



Product Catalogue



AIR HANDLING UNITS



EXHAUST HOODS



ACCESSORIES



MORE THAN PURE AIR



Airfi Oy

forerunner in the ventilation industry

Our mission is to renew the ventilation sector with the most energy-efficient devices on the market that utilize learning artificial intelligence, whose operational reliability has been proven in the extreme conditions of the Nordic winter.

Airfi designs and manufactures energy-efficient air handling units, renowned for our self-learning frostprotection system (AFPS). Airfi's product portfolio covers different types of air handling solutions for diverse needs, from single-family homes to public facilities. We also offer control hoods, central hoods, cooker hoods and related accessories.

Our devices, which utilize modern artificial intelligence, are the most energy-efficient, high quality, exceptionally reliable on the market, and their basic structure lasts the life of the building.

Our in-house team of experts handles both product development and software creation. Airfi products are proudly manufactured in Raisio, Finland. This commitment to in-house R&D fosters seamless integration and continuous improvement. As a result, we deliver cutting-edge ventilation solutions, leveraging both in-house expertise and strategic external partnerships. This translates to faster development cycles, enhanced quality control, and ultimately, superior products.

Airfi Oy AB
Piilipuunkatu 11
21200 Raisio
Finland

02 430 3300
info@airfi.fi
www.airfi.eu

Contents

Sustainability	4
Air handling units	6
dB kit for silent ventilation	7
Option table	8
Dimensional drawings	10
Air flow rate	13
Product codes	14
Controls	16
Control hoods	18
Pia control hood	20
Suvi control hood	21
Ida control hood	22
Eva control hood	23
Central hoods	24
Pia central hood	26
Suvi central hood	27
Ida central hood	28
Eva central hood	29
Cooker hoods	30
Ava cooker hood	32
Rosa cooker hood	33
Ida cooker hood	34
Eva cooker hood	35
Sara cooker hood	36
Jade cooker hood	37
Accessories	38
Duct radiators	38
Santeri damper	39

We reserve the right to make changes.

Sustainable actions for the environment

Beyond environmental protection.

Our vision extends beyond safeguarding the environment. We prioritize initiatives that contribute to long-term sustainability, including community investments and fostering a diverse workforce.

Long-term development.

As a relatively young company we embrace the opportunity to integrate sustainability into our core operations from the beginning, ensuring a future-proof and environmentally conscious foundation.

Partnering for sustainability.

We collaborate with suppliers, logistics companies, and other partners to reduce environmental impact and promote social responsibility throughout the supply chain.

Everyday actions

Multicultural organization.

We are a multicultural organization. Equality is realized in our company in such a way that everyone has the same opportunities to progress and develop.

Recycle everything.

We sort and recycle all waste generated from our operations.



Warranty 2+4 years

We believe that products should be made to last, and we are committed to designing and manufacturing products that are durable, repairable, and recyclable.

Please visit our website for the latest and most detailed warranty terms and conditions: airfi.eu

Eco-friendly by design



Minimized environmental impact

We consider the environmental impact at every stage, from design and manufacturing to materials and longevity.



Design for long lifespan

Units are built to last, minimizing waste and resource consumption far into future.



Future-proofing

Easy maintenance, and part replacements extend lifespan, reducing replacement needs.



Responsible materials

Recycled and recyclable materials are used whenever possible, with 100% recyclable metal and eco-friendly coatings.



Optimized packaging

Unit packaging is designed for optimized pallet transportation, eliminating wasted space.



Minimized manufacturing waste

Through thoughtful design and responsible practices, our manufacturing process generates minimal waste.

Air handling units

Airfi air handling units enable fresh and healthy indoor air. The new Airfi air handling units are designed for the demanding conditions of the North. The Airfi range offers the right unit type for single-family homes, terraced houses, apartment buildings, public facilities and offices. Airfi units have enhanced dehumidification through the bottom of the unit to ensure efficient and energy-friendly operation during cold periods.

Airfi Model 60, Model 100 and Model 130 air handling units are just 558 mm wide and they can be installed inside a cabinet.



Humidity automation
The most intelligent demand-controlled humidity automation on the market as standard (models 60, 100, 130 and 150).



High living comfort
The energy-efficient and quiet unit is easy and effortless to use.



Quick installation
Quick and easy installation on a ceiling bracket.



Uniform temperature
Intelligent cascade-controlled bypass damper that takes temperature variations into account.



AFPS™ technology
The AFPS™ hoarfrost protection ensures continuous ventilation in your home.



Unit controls
The unit can be controlled with a control panel or the Airfi App.



Condensate removal
Thanks to the sloping inner bottom, condensation water is efficiently removed.



Building automation control systems
Connectivity to common home automation systems as standard.



**Model
60**



**Model
100**



**Model
130**



**Model
150**



**Model
250/350**

dB kit for silent ventilation

Our **dB kit** has been developed according to customer requirements for applications where the noise level should be minimal. The noise levels of the dB kit have been measured by an external accredited laboratory.

On our website, you will find a link to a calculation programme that makes it easy to see the effect of the dB kit on the noise coming through the sheath. The calculation programme shows the dB value of a so-called "hard room" (e.g. a bathroom) and a normal habitable room.

Calculation programme



Direct link to the calculation programme

You can also find the calculation programme on our website at airfi.fi.



Components

1. Front strip (2 pcs)
2. Insulating plate, 40 mm
3. Insulating plate retaining strip (2 pcs)
4. Connector bolt M6 (4 pcs)
5. Door sealing tape
6. Door mass-type plate
7. Resonance insulation (2 pcs)

NB: The basic dB kit does not include the cabinet frame and door.

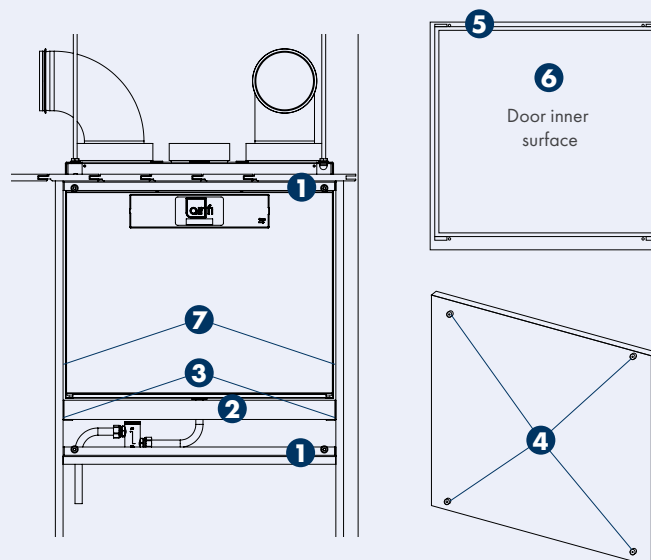

Technical specifications



Model 60



Model 100



Model 130

Dimensions (width x height x depth)	558 x 450 x 558	558 x 490 x 558	558 x 490 x 558
Weight	41 kg	42,5 kg	44 kg
Duct outlets	4 x 160, 1 x 125	4 x 160, 1 x 125	4 x 160, 1 x 125
Kitchen bypass	●	●	●
Condensate fitting	Centre, 66 mm from rear edge	Centre, 66 mm from rear edge	Centre, 66 mm from rear edge
Condensation water tray	Tilted condensation water tray	Tilted condensation water tray	Tilted condensation water tray
Max. extract air flow rate (100 Pa)	385 m ³ /h (107 dm ³ /s)	385 m ³ /h (107 dm ³ /s)	511 m ³ /h (142 dm ³ /s)
Max. supply air flow rate (100 Pa)	356 m ³ /h (99 dm ³ /s)	342 m ³ /h (95 dm ³ /s)	450 m ³ /h (125 dm ³ /s)
Specific energy consumption (SEC) in a cold climate	A+	A+	A+
Specific energy consumption (SEC) in an average climate	A	A	A
Extract air heat recovery annual efficiency class	A+/A (kitchen bypass in use)	A+/A (kitchen bypass in use)	A+/A (kitchen bypass in use)
Air handling unit's specific electrical power class at rated air flow	A	A	A
Electricity	230 V, 50 Hz, 10 A, max.1165 W: Plug	230 V, 50 Hz, 10 A, max.1165 W: Plug	230 V,50 Hz,10 A, max.1255 W: Plug
Apartment size max. m ² *	200 m ²	200 m ²	250 m ²
Summer/winter function			
Automatic, adjustable	●	●	●
Defrosting automation			
Continuous supply air, AFPS	●	●	●
Post heater			
	920 W (electric)	920 W (electric)	920 W (electric)
Equipment			
Ceiling mount bracket	●	●	●
Wall mount bracket	●	●	●
Stand	-	-	-
Vapour barrier filler plate	●	●	●
Humidity transmitter (internal)	●	●	●
Humidity transmitter	●	●	●
Carbon-dioxide transmitter	●	●	●
Cooling radiators	●	●	●
Filter guard	●	●	●
Constant pressure control	●	●	●
Spring return damper	●	●	●
Airfi KNX adapter	●	●	●
Controls			
Uno, Sento, Mille-Wire, Mille-Wifi	●	●	●
Control hoods	●	●	●
VAK, DDC, 10VDC, Transmitter controls Modbus RTU/TCP, Ethernet	●	●	●

● Standard equipment

● Accessory

*Implementation according to designer's ventilation plan.



Dimensions (width x height x depth)	700 x 850 x 645	998 x 1475 x 650	998 x 1475 x 650
Weight	81 kg	168 kg	168 kg
Duct outlets	4 x 200	4 x 250	4 x 250
Kitchen bypass	-	-	-
Condensate fitting	Centre, 110 mm from rear edge	From the front edge 128 mm	From the front edge 128 mm
Condensation water tray	Tilted condensation water tray	Tilted condensation water tray	Tilted condensation water tray
Max. extract air flow rate (100 Pa)	648 m ³ /h (180 dm ³ /s)	Electric 954 m ³ /h (265 dm ³ /s) Water 954 m ³ /h (265 dm ³ /s)	Electric 1325 m ³ /h (368 dm ³ /s) Water 1325 m ³ /h (368 dm ³ /s)
Max. supply air flow rate (100 Pa)	572 m ³ /h (159 dm ³ /s)	Electric 893 m ³ /h (248 dm ³ /s) Water 875 m ³ /h (243 dm ³ /s)	Electric 1256 m ³ /h (349 dm ³ /s) Water 1242 m ³ /h (345 dm ³ /s)
Specific energy consumption (SEC) in a cold climate	A+	A+	A+
Specific energy consumption (SEC) in an average climate	A	A	A
Extract air heat recovery annual efficiency class	A+	A+	A+
Air handling unit's specific electrical power class at rated air flow	A	A	A
Electricity	230 V, 50 Hz, 16 A, max. 2200 W: Plug	Electric 230 V 16 A, max. 3500 W Water 230 V 10 A, max. 1100 W	Electric 400 V 3 x 16 A, max. 8250 W Water 230 V 10 A, max. 1100 W
Apartment size max. m ² *	300 m ²	450 m ²	550 m ²
Summer/winter function			
Automatic, adjustable	●	●	●
Defrosting automation			
Continuous supply air (AFPS)	●	● block defrosting	● block defrosting
Post heater			
	2 x 920 W (electric)	2380 W (electric) / water	3 x 2380 W (electric) / water
Equipment			
Ceiling mount bracket	-	-	-
Wall mount bracket	●	-	-
Mounting set	●	●	●
Vapour barrier filler plate	●	-	-
Humidity transmitter (internal)	●	●	●
Humidity transmitter	●	●	●
Carbon-dioxide transmitter	●	●	●
Cooling radiators	●	●	●
Filter guard	●	●	●
Constant pressure control	●	●	●
Spring return damper	●	●	●
Airfi KNX adapter	●	●	●
Controls			
Uno, Sento, Mille-Wire, Mille-Wifi	●	●	●
Control hoods	●	●	●
VAK, DDC, 10VDC, Transmitter controls Modbus RTU/TCP, Ethernet	●	●	●

● Standard equipment

● Accessory

* Implementation according to designer's ventilation plan.

Dimensional drawings



Model 60



Model 100/130



Model 150

Front

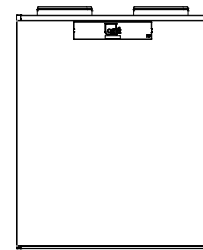
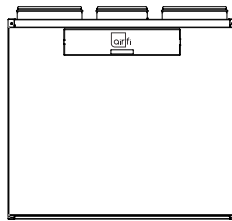
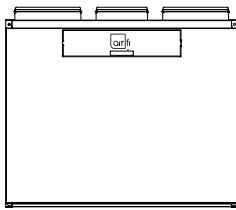

Side

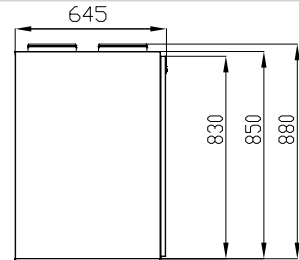
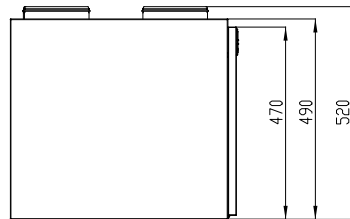
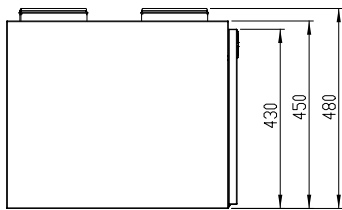

Model R

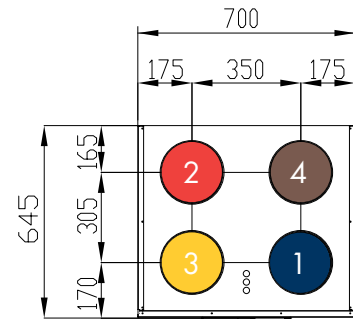
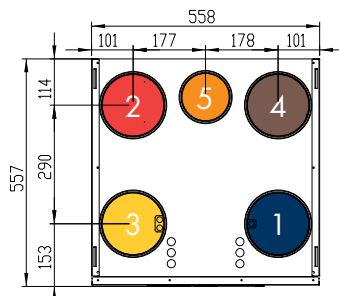
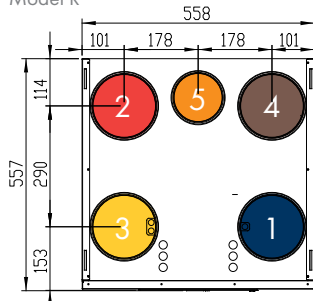

Model L

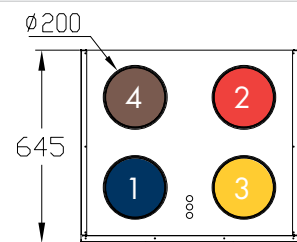
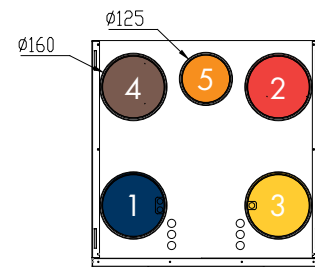
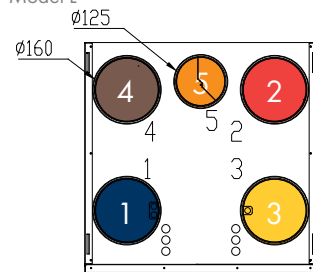

Bottom

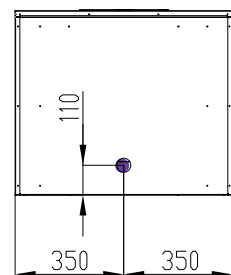
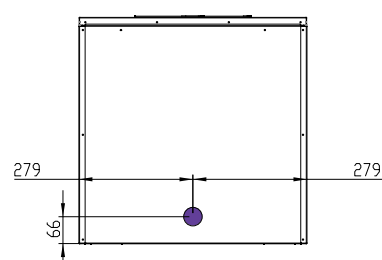
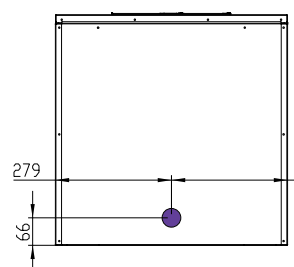



Model 250



Model 350

Front

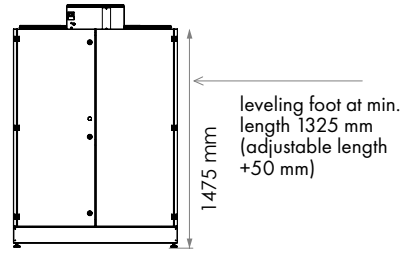
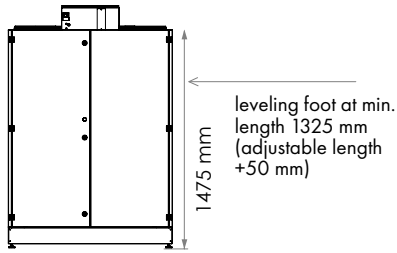

Side

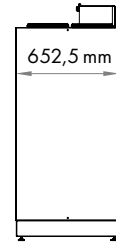
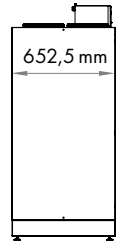

Model R

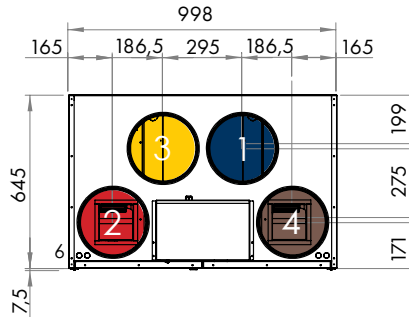
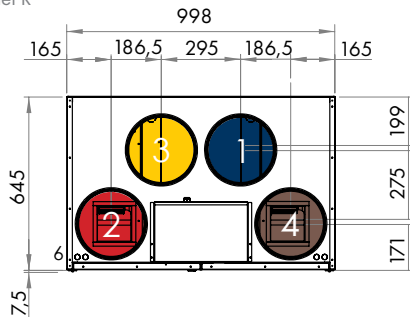

Model L

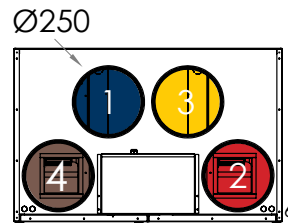
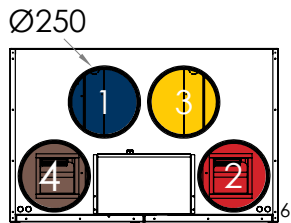

Bottom

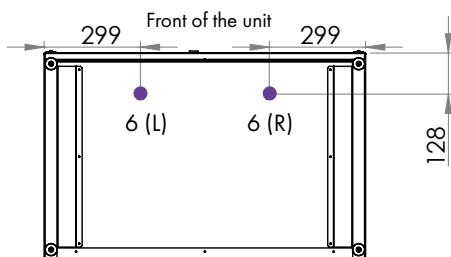
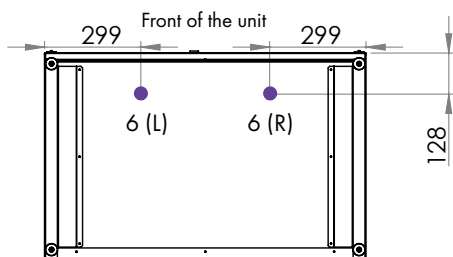



Air flow rate

Model 60

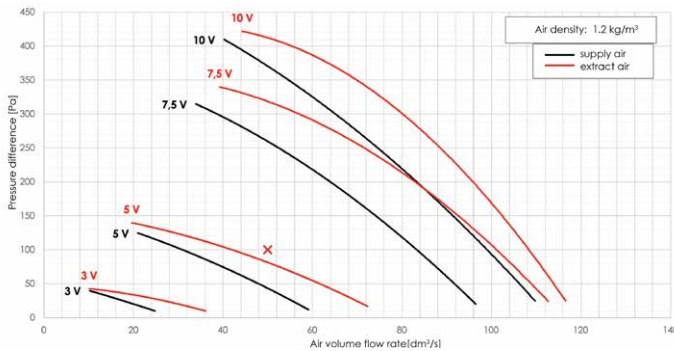

Model 100

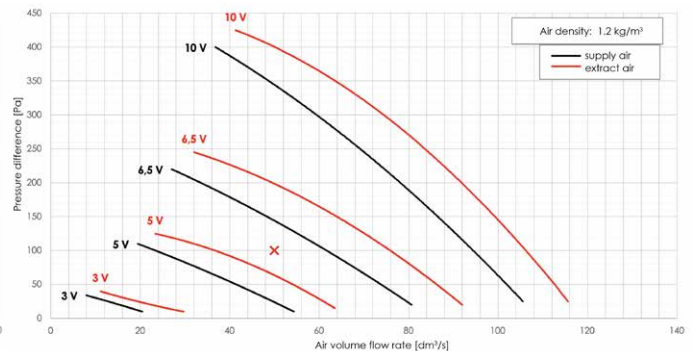

Model 130

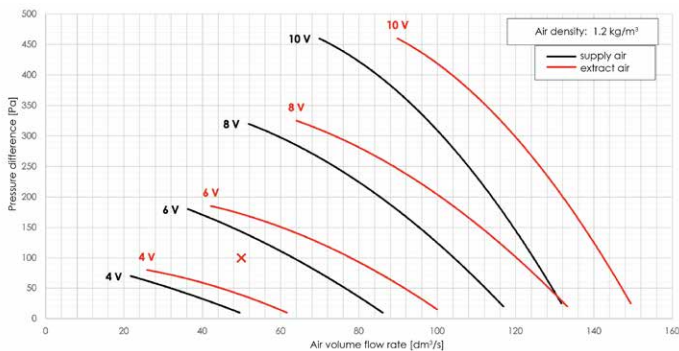

Model 150

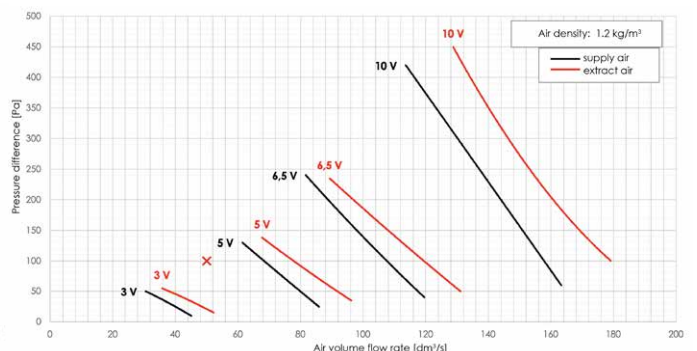

Model 250

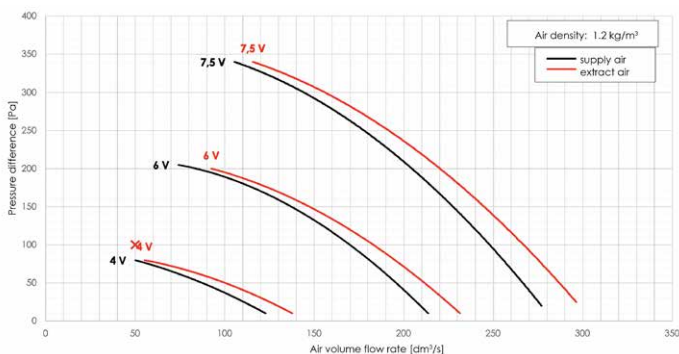

Model 350

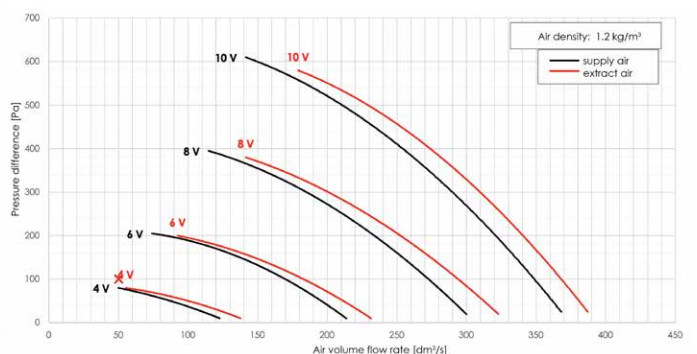

Calculation programme

The Airfi calculation programme calculates accurate octave-band sound power levels of the air flow in the duct system and the environment. The programme also calculates the control percentages for both fans and the SFP value according to the given air flow and duct pressure drop. The programme also shows the unit's annual efficiency. This document can also be used as an appendix to an application for a building licence.



Direct link to the calculation programme!

Or find the calculation programme on our website at www.airfi.fi.

Product codes

Air handling units

Model	Code	HVAC number
Model 60 (R) Electric	10060011	7916041
Model 60 (L) Electric	10060021	7916042
Model 100 (R) Electric	10100011	7916043
Model 100 (L) Electric	10100021	7916044
Model 130 (R) Electric	10130011	7916091
Model 130 (L) Electric	10130021	7916092
Model 150 (R) Electric	10150011	7916045
Model 150 (L) Electric	10150021	7916046
Model 250 (R) Electric	10250011	7916083
Model 250 (L) Electric	10250021	7916082
Model 250 (R) Water	10250012	7916088
Model 250 (L) Water	10250022	7916090
Model 350 (R) Electric	10350011	7916084
Model 350 (L) Electric	10350021	7916085
Model 350 (R) Water	10350012	7916086
Model 350 (L) Water	10350022	7916087

Accessories

Model	Code	HVAC number
Ceiling mount bracket 160-125-K: Model 60, 100, 130	40000013	7916031
Ceiling mount bracket 160-160-K: Model 60, 100, 130	40000014	7916032
Vapour barrier filler plate: Model 60/100/130	40000015	7916033
Wall bracket: Model 60/100/130	40000016	7916034
Mounting set: Model 150	40000039	7916037
Airfi water seal chrome-plated	40000053	7916072
Filter set no 1, Model 60/100/130	40000001	7916035
Filter set no 2, Model 150	40000002	7916036
Filter set no 3, Model 250/350	40000003	7916089
dB kit, Model 60/100/130	40000089	-
Airfi KNX adapter	40000098	-
Constant pressure control, supply *	40000092	-
Constant pressure control, extract *	40000093	-
Spring return damper ø250 mm, outdoor air *	40000094	-
Spring return damper ø250 mm, exhaust air *	40000095	-
Filter guard, supply *	40000096	-
Filter guard, extract *	40000097	-

* Factory fitting Model 250/350

Model 60
with ceiling mount bracket
and Airfi water seal



Airfi water seal
40 000 053

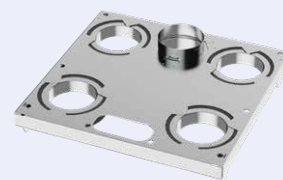

Ceiling mount bracket 160-125-K
40 000 013

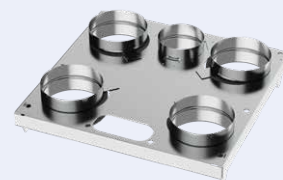

Ceiling mount bracket 160-160-K
40 000 014

Controls

With simple and modern controls, you can easily control the air handling unit. You can also download the Airfi App to your existing smart devices.



Mille Wi-Fi



Mille WIRE

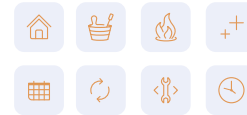

Sento



Uno

The Uno control panel has five speeds.



At home/Away



Service panel



Control multiple units



Sauna function



Booster



Wireless control



Fireplace function



Schedule



Time and date

Airfi App

The app allows you to control your air handling unit wirelessly via Wi-Fi



Model	Code	HVAC number
5-speed Uno rotary switch	4000040	7916038
Capacitive Sento controller	4000041	7916039
Mille-Wifi controller	4000042	7916040
Mille-Wire controller	4000052	7916065



AFPS™ Airfi Frost Pro System

Welcome to the A+ energy efficiency generation.

With the AFPS technology, the annual efficiency rating of Airfi Oy's air handling units is A+.

Airfi Frost Pro System (AFPS) is standard in all air handling units manufactured by Airfi Oy. The new Airfi Frost Pro System (AFPS) is a self-learning hoarfrost protection system which guarantees excellent performance during cold periods.

Airfi Frost Pro System is a Finnish invention, where the heat exchanger is defrosted only when there is a need for it. This way the air handling unit works in prolonged freezing weather.

The energy used to defrost the heat exchanger is taken from the extract air. This way, the energy provided by the heating resistors is used in the apartment rather than, for example, heating the exhaust air with the front resistors.

The defrosting function is used optimally, saving energy compared to older solutions. The self-learning capabilities make it possible to take the individual characteristics of the air handling unit into account, for example, how dirty the filters and heat recovery cell are. By choosing an energy-efficient air handling unit from Airfi Oy, you will save significant amounts of energy.



EXHAUST HOODS

Control hoods

Airfi's control hoods are designed to control not only the fume extraction, but also the individual air handling unit or the roof ventilator.



Washable grease filter
Metallic machine-washable grease filter.



Fixed structure
Durable product with a metal structure.



LED lights
Ecological and long-lasting LED lights.



Quick to install
Easy and quick to install.



Ventilation
Control hoods are suitable for controlling your home's air handling system or roof ventilator.



Plug connection
A safe and fast connector for all hoods.



Safera safety technology
Some products are compatible with Safera safety technology.



airfi

- + 4 G

Suvi control hood
also available in silver or black





AC/EC
Control

See p. 25 for the hood installed.

Pia control/booster hood

A classic cabinet-mounted control hood that can be quickly installed in cabinets of different depths.

Details

- LED lights, 2 x 4000 K
- Width 500 and 600 mm
- Fixed structure, with plug
- Back cover strip included in the delivery
- Duct connection 1 x 125 mm
- Machine-washable metal grease filter
- Available with Safera safety technology
- Booster valve with timer (60 min)
- Control hood: Boosted ventilation and vacuum compensation during cooking
- Booster hood: Boost status to external systems
- AC control, max 350 W
- EC control: Continuous control (default) or stopping mode

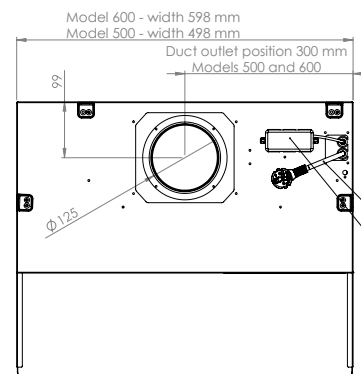
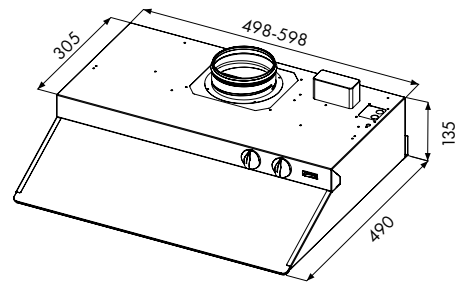

Model	Code	HVAC number	Width	Colour	Control
Pia-SA50w	20 000 017	7916013	500	White	1-5
Pia-SA60w	20 000 018	7916014	600	White	1-5
Pia-SA58w	20 000 041	7916056	500	White	Booster
Pia-SA68w	20 000 042	7916059	600	White	Booster
Pia-SA57w-AC-EC	20 000 056	7916095	500	White	AC/EC
Pia-SA67w-AC-EC	20 000 057	7916096	600	White	AC/EC

Accessory

	Code
Safera Siro or integrated Sense unit, depending on the hood type	40 000 054
Stove power control unit Safera PCU6.3, 3 x 16 A 400 V	40 000 056
Safera leak guard	40 000 057



AC/EC
Control

See p. 19 for the hood installed and pulled out.

Suvi control/booster hood

Pull-out control hood integrated in a cabinet. Airfi's control hoods are designed to control not only the smoke removal system, but also the individual air handling unit or roof ventilator.

Details

- Control hood: Boosted ventilation and vacuum compensation during cooking
- Booster hood: Boost status to external systems
- EC control: Continuous control (default) or stopping mode
- Accessories: AC control unit, electronic hoods, max 350 W (Airfi product code 40 000 063)

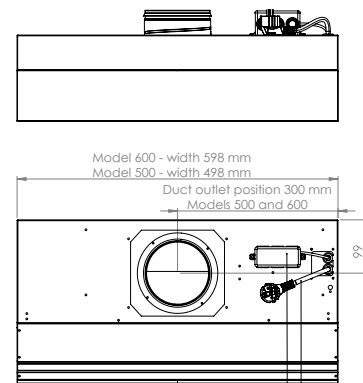
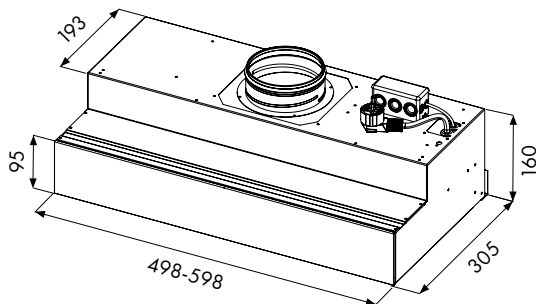

Model	Code	HVAC number	Width	Colour	Control
Suvi-CF50w	20000025	7916021	500	White	1-5
Suvi-CF60w	20000026	7916022	600	White	1-5
Suvi-CF50s	20000027	7916023	500	Silver	1-5
Suvi-CF60s	20000028	7916024	600	Silver	1-5
Suvi-CF50b	20000031	7916027	500	Black	1-5
Suvi-CF60b	20000032	7916028	600	Black	1-5
Suvi-CF58w	20000043	7916058	500	White	Booster
Suvi-CF68w	20000044	7916059	600	White	Booster
Suvi-CF58s	20000047	7916062	500	Silver	Booster
Suvi-CF68s	20000048	7916063	600	Silver	Booster
Suvi-CF58b	20000045	7916060	500	Black	Booster
Suvi-CF68b	20000046	7916061	600	Black	Booster



Ida control hood/booster hood

AC/EC
Control

A wall-mounted model with optional placement. The hood has capacitive switches integrated in the front panel. For controlling an Airfi air handling unit and an EC roof ventilator.

Details

- 2 x LED lights, 4000 K
- Width 600 and 900 mm
- Booster valve with electronic timer (60 min)
- Duct connector size 1 x 125 mm
- Duct cover included in delivery
- Boosted ventilation and vacuum compensation during cooking (Set during commissioning. This function can also be overridden.)
- EC control: Continuous control (default) or stopping mode
- Accessories: AC control unit, electronic hoods, max 350 W (Airfi product code 40 000 063)

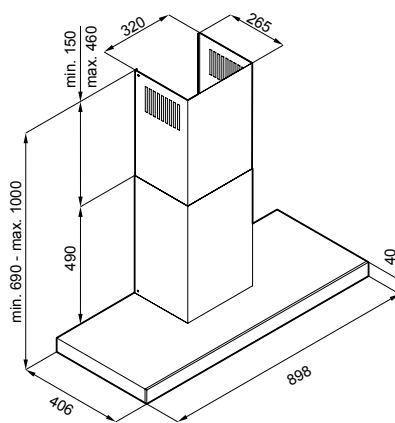
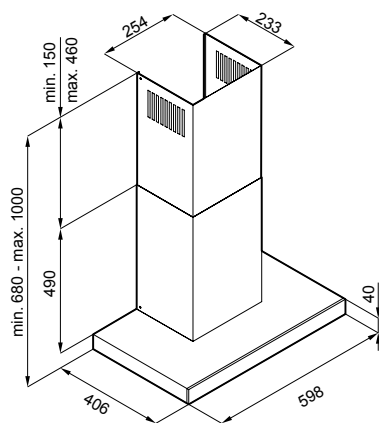

Model	Code	HVAC number	Width	Colour	Control
Ida-CC60s	20 000 037	7916052	600	Black/stainless	1-5
Ida-CC90s	20 000 038	7916053	900	Black/stainless	1-5
Ida-CC68s	20 000 049	7916047	600	Black/stainless	Booster
Ida-CC98s	20 000 050	7916048	900	Black/stainless	Booster
Ida-CC60w	20 000 058	7916076	600	White	1-5
Ida-CC90w	20 000 059	7916077	900	White	1-5
Ida-CC68w	20 000 064	7916097	600	White	Booster
Ida-CC98w	20 000 065	7916098	900	White	Booster



Eva control hood/booster hood

AC/EC
Control

Freely mounted island-type model with adjustable installation height. The hood has capacitive switches integrated in the front panel. For controlling an Airfi air handling unit and an EC roof ventilator.

Details

- 4 x LED lights, 4000 K
- Booster valve with electronic timer (60 min)
- Duct connector size 1 x 125 mm
- Duct cover included in delivery
- Boosted ventilation and vacuum compensation during cooking (Set during commissioning. This function can also be overridden.)
- EC control: Continuous control (default) or stopping mode
- Accessories: AC control unit, electronic hoods, max 350 W (Airfi product code 40 000 063)

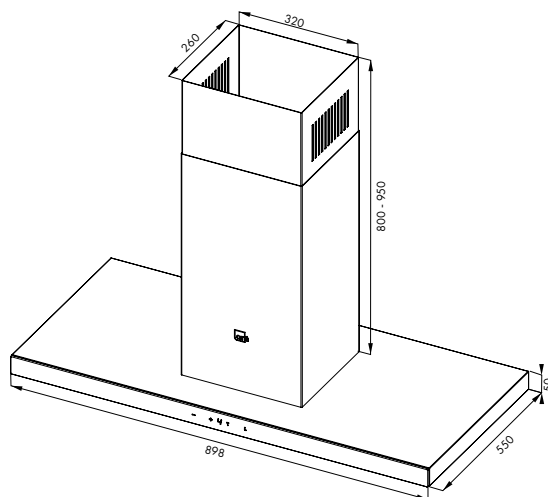

Normal adjustment tolerance for mounting protection and duct cover 800–950 mm

Shorter option (650–800 mm) is available upon request. Please specify when ordering.

Model	Code	HVAC number	Width	Colour	Control
Eva-CD90s	20 000 040	7916055	900	Black/stainless	1–5
Eva-CD98s	20 000 051	7916049	900	Black/stainless	Booster
Eva-CD90w	20 000 060	7916078	900	White	1–5
Eva-CD98w	20 000 066	7916099	900	White	Booster

EXHAUST HOODS

Central hoods

Airfi central hoods are designed for centralised air handling systems. The hood is designed to make installation and adjustment easy and effortless. Performance values are measured with a pressure gauge without separate measuring hooks. From the same point, the desired normal air flow rate and the desired enhanced air flow rate can be measured. The removable fire valve is located behind the grease filter.

Airfi central hoods meet the airborne sound insulation requirements of the relevant building regulations. All the central hoods also comply with the measurement standard SFS-EN-ISO 10140-2 and ISO 717-1.



Washable grease filter
Metallic machine-washable grease filter.



Fixed structure
Durable product with a metal structure.



LED lights
Ecological and long-lasting LED lights.



Quick to install
Easy and quick installation.



Fire valve
Safe and type-approved



Soundproofed
Silent running sound.



Effective fume removal
The hood allows for effective fume removal.



Safera safety technology
Some products are compatible with Safera safety technology.



Pia central hood
timeless design in white





See p. 25 for the hood installed.

Pia central hood

A classic cabinet-mounted central hood for centralised air handling systems. Quick to install in cabinets of different depths. The removable smoke limiting valve is located behind the grease filter.

Details

- LED lights, 2 x 3 W 4000 K
 - Width 500 and 600 mm
 - Type-approved fire valve
 - Fixed structure, with plug
 - Booster valve with mechanical timer (60 min)
 - Signal of flap position:
 1. Voltage-free status signal (standard)
 2. Compensating damper 24VDC control (max. 7 W) (accessory 40 000 062)
 3. Compensating damper 230VAC control (standard)
- NB: Choose the right connection cable between the compensating device and the hood.
- Back cover strip included in the delivery
 - Duct connection 1 x 125 mm
 - Machine-washable metal grease filter
 - Available with Safera safety technology

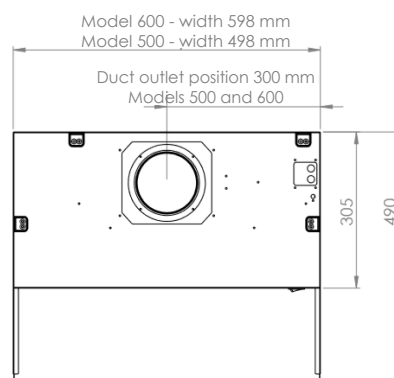
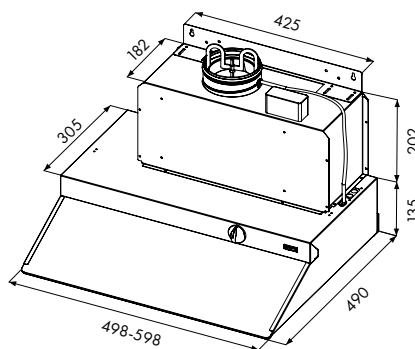

Model	Code	HVAC number	Width	Colour
Pia-SA55w	20000015	7916011	500	White
Pia-SA65w	20000016	7916012	600	White

Accessory	Code
Transformer 230 VAC–24 VDC for compensating damper control	40000062
Safera Siro or integrated Sense unit, depending on the hood type	40000054
Stove power control unit Safera PCU6.3, 3x16A 400 V	40000056
Safera leak guard	40000057



See p. 19 for the hood **installed and pulled out**.

Suvi central hood

Pull-out central hood integrated in a cabinet. Airfi central hoods are designed for centralised air handling systems. Quick to install in cabinets of different depths. The removable smoke limiting valve is located behind the grease filter.

Details

- LED lights, 2 x 4000 K
- Width 500 and 600 mm
- Type-approved fire valve
- Pull-out, with plug
- Booster valve with timer
- Signal of flap position:
 1. Voltage-free status signal (standard)
 2. Compensating damper 24VDC control max. 7 W (standard)

NB: When connected, a short-circuit element is used to select whether to use voltage-free or 24VDC compensation data.

- Touch keypad integrated in the glass
- Back cover strip included in the delivery
- Duct connection 1 x 125 mm
- Machine-washable metal grease filter

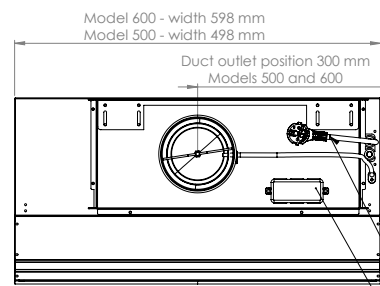
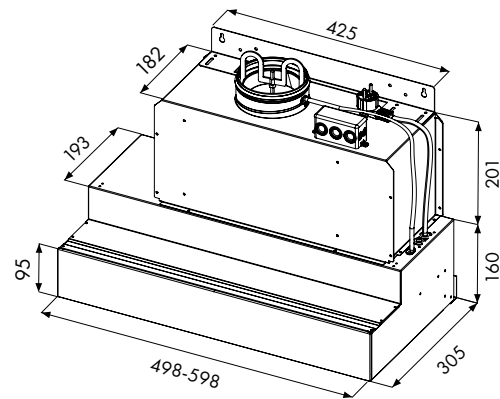

Model	Code	HVAC number	Width	Colour
Suvi-CF55w	20000021	7916017	500	White
Suvi-CF65w	20000022	7916018	600	White
Suvi-CF55s	20000023	7916019	500	Silver
Suvi-CF65s	20000024	7916020	600	Silver
Suvi-CF55b	20000033	7916029	500	Black
Suvi-CF65b	20000034	7916030	600	Black



Ida central hood

A wall-mounted model with optional placement. The hood has capacitive switches integrated in the front panel. Airfi central hoods are designed for centralised air handling systems.

Details

- LED lights, 2 x 4000 K
- Width 600 and 900 mm
- Booster valve with timer
- Duct connector size 1 x 125 mm
- Type-approved fire valve
- Machine-washable metal grease filter
- Signal of flap position:
 1. Voltage-free status signal (standard)
 2. Compensating damper 24VDC control max. 7 W (standard)

NB: When connected, a short-circuit element is used to select whether to use voltage-free or 24VDC compensation data.

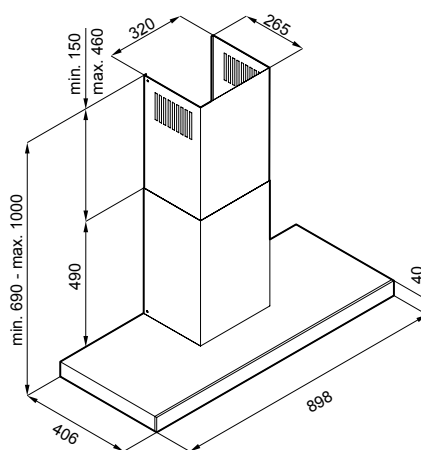
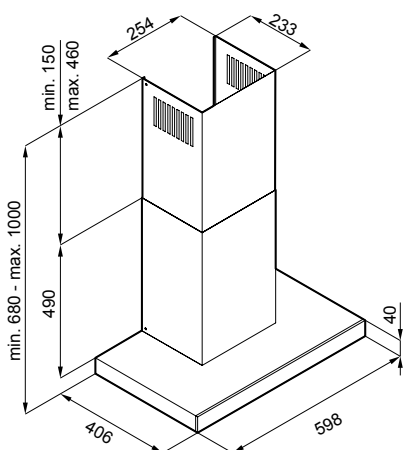

Model	Code	HVAC number	Width	Colour
Ida-CC65s	20000035	7916050	600	Black/stainless
Ida-CC95s	20000036	7916051	900	Black/stainless
Ida-CC65w	20000061	7916079	600	White
Ida-CC95w	20000062	7916080	900	White



Eva central hood

Freely mounted island-type model. The hood has capacitive switches integrated in the front panel. Airfi central hoods are designed for centralised air handling systems.

Details

- LED lights, 4 x 4000 K
- Duct connector size 1 x 125 mm
- Booster valve with timer
- Type-approved fire valve
- Machine-washable metal grease filter
- Signal of flap position:
 1. Voltage-free status signal (standard)
 2. Compensating damper 24VDC control max. 7 W (standard)

NB: When connected, a short-circuit element is used to select whether to use voltage-free or 24VDC compensation data.

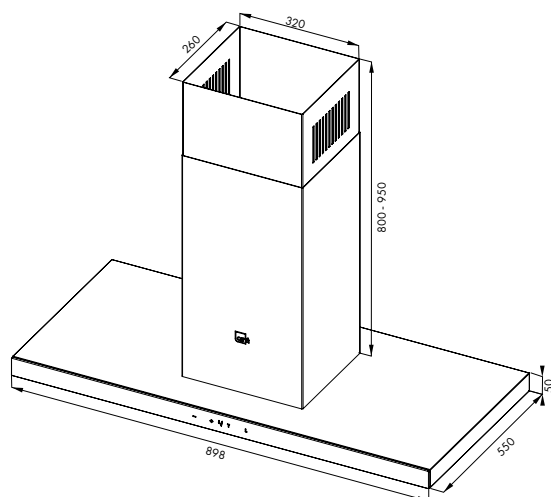

Normal adjustment tolerance for mounting protection and duct cover 800–950 mm

Shorter option (650–800 mm) is available upon request. Please specify when ordering.

Model	Code	HVAC number	Width	Colour
Eva-CD95s	20000039	7916054	900	Black/stainless
Eva-CD95w	20000063	7916081	900	White

EXHAUST HOODS

Cooker hoods

Airfi's portfolio also includes cooker hoods. Cooker hoods always have an integrated fan. An optional charcoal filter is also available for Airfi cooker hoods if the exhaust of extract air is not possible.



Washable grease filter
Metallic machine-washable grease filter.



Fixed structure
Durable product with a metal structure.



LED lights
Ecological and long-lasting LED lights.



Quick to install
Easy and quick to install.



A simple solution
Better air quality in an old kitchen with a charcoal filter



Plug connection
A safe and fast connector for all hoods.



Charcoal filter
Optional charcoal filters are available for cooker hoods



Easy to use
Simple control panel



Eva cooker hood
with adjustable installation height





Ava cooker hood

Pull-out cooker hood integrated in a cabinet. The cooker hood has capacitive switches integrated in the front panel. A model with its own fan and cable coupling.

Details

- 2 x LED lights, 3400 K
- Duct connector size 1 x 120 mm
- Minimum/maximum suction power 275/500 (m³/h)
- Sound levels: min. 48 dB / max. 50 dB
- 85 W motor
- Energy class D
- Available with a charcoal filter

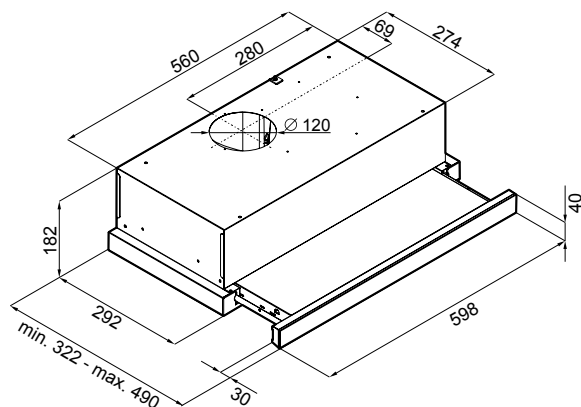

Model	Code	HVAC number	Width	Colour
Ava-CB61w	20000007	7916004	600	White
Ava-CB61b	20000008	7916005	600	Black
Accessory			Code	HVAC number
Charcoal filter Ava-CB61s, Ava-CB61w			40000032	7916070



Rosa cooker hood

Pull-out cooker hood integrated in a cabinet. There is an electric switch on the hood body A model with its own fan and cable coupling.

Details

- 2 x LED lights, 3400 K
- Width 500 and 600 mm
- Duct connector size 1 x 120 mm
- Minimum/maximum suction power: 135–141/190–198 (m³/h)
- Sound levels: min. 48 dB / max. 50 dB
- 90 W motor
- Energy class D
- Available with a charcoal filter

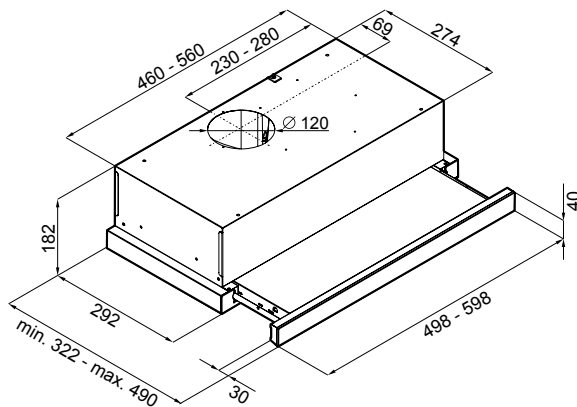

Model	Code	HVAC number	Width	Colour
Rosa-SC51w	20000003	7916000	500	White
Rosa-SC61w	20000004	7916001	600	White
Rosa-SC51s	20000005	7916002	500	Stainless
Rosa-SC61s	20000006	7916003	600	Stainless

Accessory	Code	HVAC number
Charcoal filter Rosa-SC61s, Rosa-SC61w, Rosa-SC51s, Rosa-SC51w	40000033	7916071



Ida cooker hood

A wall-mounted model with optional placement. The cooker hood has capacitive switches integrated in the front panel. A model with its own fan and cable coupling.

Details

- 2 x LED lights, 3400 K
- Width 600 and 900 mm
- Exhaust hood timer 10–90 min.
- Duct connector size 1 x 150 mm
- Minimum/maximum suction power 275/500 (m³/h)
- Sound levels: min. 50–52 dB/max. 63–66 dB
- 250 W motor
- Energy class C
- Available with a charcoal filter

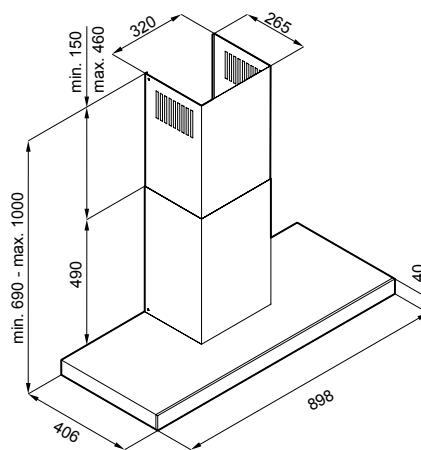
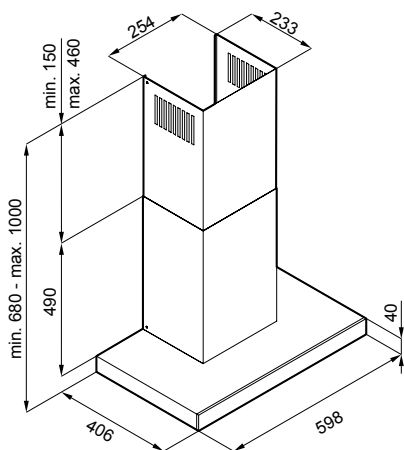

Model	Code	HVAC number	Width	Colour
Ida-CC61s	20000009	7916006	600	Black/stainless
Ida-CC91s	20000010	7916007	900	Black/stainless
Accessory	Code	HVAC number		
Charcoal filter Ida-CC61s	40000031	7916069		
Charcoal filter Eva-CD91s, Ida-CC91s	40000030	7916068		



Eva cooker hood

Freely mounted island-type model with adjustable installation height. The cooker hood has capacitive switches integrated in the front panel. A model with its own fan and cable coupling.

Details

- 4 x LED lights, 3400 K
- Exhaust hood timer 10–90 min.
- Duct connector size 1 x 150 mm
- Minimum/maximum suction power 320/530 (m³/h)
- Sound levels: min. 52 dB / max. 66 dB
- 275 W motor
- Energy class B
- Duct cover included in delivery
- Available with a charcoal filter

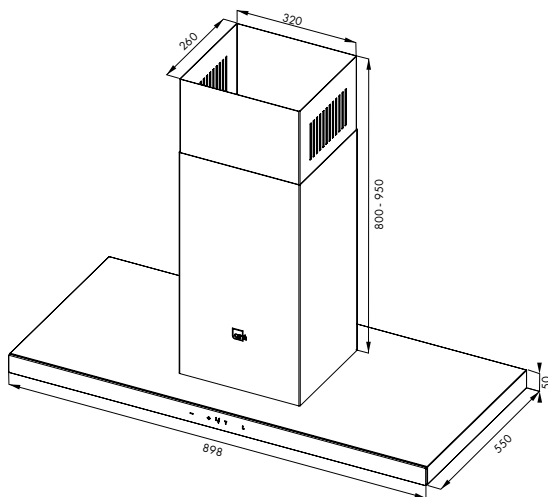

Model	Code	HVAC number	Width	Colour
Eva-CD91s	20000011	7916008	900	Black/stainless
Accessory			Code	HVAC number
Charcoal filter Eva-CD91s, Ida-CC91s			40000030	7916068



Sara cooker hood

Freely mounted island-type cooker hood. Anthracite shell with electronic soft touch controls. Machine-washable grease filter. Cable coupling.

Details

- LED lights, 3400 K
- Exhaust hood timer 10–90 min.
- Duct connector size 1 x 120 mm
- Minimum/maximum suction power 278/510 (m³/h)
- Sound levels: min. 52 dB / max. 62 dB
- 250 W motor
- Energy class B
- Available with a charcoal filter

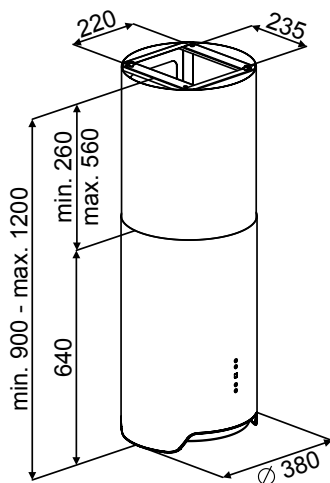

Model	Code	HVAC number	Colour
Sara-EA01 a	20000012	7916009	Anthracite
Accessory	Code	HVAC number	
Charcoal filter Sara-EA01 a	40000029	7916067	



Jade cooker hood

Ceiling-mounted island-type cooker hood. Controllable by remote control or from the screen with a capacitive controller. Machine-washable grease filters. Four different suction power levels.

Details

- 4 x LED lights, 3400 K
- Exhaust hood timer 10–90 min.
- Duct connector size 1 x 150 mm
- Minimum/maximum suction power 260/585 (m³/h)
- Sound levels: min. 52 dB / max. 62 dB
- 250 W motor
- Energy class C
- Remote controller included
- Available with a charcoal filter
- The fan unit can also be placed further into the duct system.

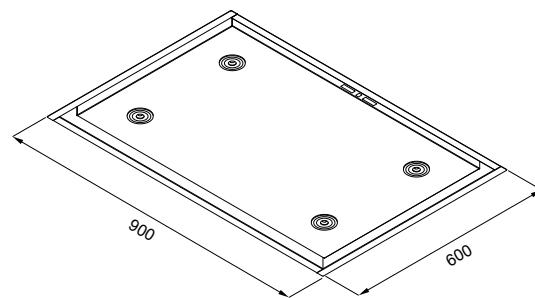
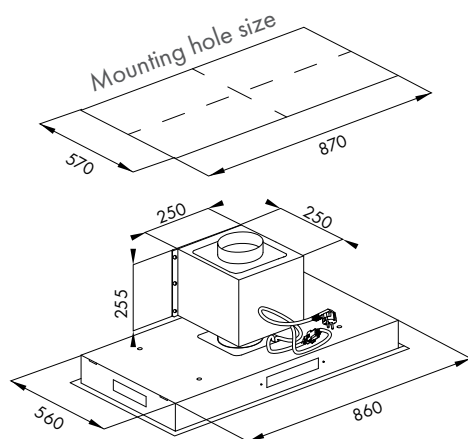

Model	Code	HVAC number	Colour
Jade-EB01w	20000013	7916010	White
Accessory	Code	HVAC number	
Charcoal filter Jade-EB01w	40000028	7916066	

Accessories

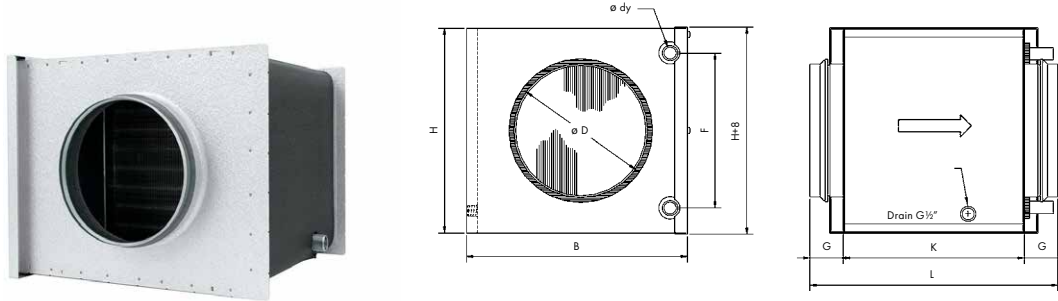

Duct radiators

CWK series water-cooled circular duct heaters are used to cool the air circulating in the air handling system. The CWK model can also be used on its own to cool individual rooms or areas.

Air flow rate	Pressure losses	Air in	Air in	Air out	Power	Water flow	Pressure loss on water side
m ³ /h	Pa	°C	% RH	°C	kW	l/s	kPa
Power CWK 160-3-2,5							
145	9	25	50	13,1	0,7	0,03	4,4
145	10	30	45	13,9	1,1	0,04	9,8
250	21	25	50	14,4	1,1	0,04	9,4
250	22	30	45	15,9	1,6	0,06	20,2
355	38	25	50	15,3	1,3	0,05	14,6
355	40	30	45	17,3	2,0	0,08	31,2
Power CWK 200-3-2,5							
255	9	25	50	13,4	1,2	0,05	2,5
255	9	30	45	14,1	1,9	0,07	5,8
390	16	25	50	14,2	1,7	0,07	4,7
390	17	30	45	15,5	2,5	0,10	10,3
555	29	25	50	15,1	2,1	0,08	7,4
555	30	30	45	16,8	3,2	0,13	16,1
Power CWK 250-3-2,5							
360	7	25	50	13,1	1,7	0,07	2,3
360	8	30	45	13,6	2,7	0,11	5,4
630	17	25	50	14,1	2,7	0,11	5,3
630	18	30	45	15,4	4,1	0,16	11,5
900	29	25	50	15,0	3,5	0,14	8,4
900	31	30	45	16,8	5,3	0,21	17,8

Malli	ØD	B	H	Ø dy	F	G	K	L	Piping internal volume	Weight	Code	HVAC number
	mm	mm	mm	mm	mm	mm	mm	mm		kg		
CWK 125-3-2,5	125	326	255	10	175	35	280	350	0,4 l	6 kg	40 000 044	-
CWK 160-3-2,5	160	326	255	10	175	40	280	360	0,4 l	6 kg	40 000 045	7916073
CWK 200-3-2,5	200	411	330	22	250	40	280	360	0,7 l	9 kg	40 000 046	7916074
CWK 250-3-2,5	250	486	405	22	325	40	280	360	1,1 l	11 kg	40 000 047	7916075
CWK 315-3-2,5	315	560	504	22	400	40	280	360	1,6 l	15 kg	40 000 091	-



Santeri damper

The installed and adjusted compensating unit balances the vacuum during the boost of the general exhaust and the exhaust hood. Vacuum balancing is achieved by the compensating unit receiving a signal from the exhaust hood when the hood's boost damper is opened, thus increasing the corresponding amount of supply air flow to the apartment.

Example

The damper unit can be used to balance the ventilation. For example, in a block of flats, the negative pressure caused by an exhaust hood's booster function can be compensated by increasing the supply air flow rate.

NB: Make sure the units can be maintained and regulated. Take into account cleaning hatches if necessary.

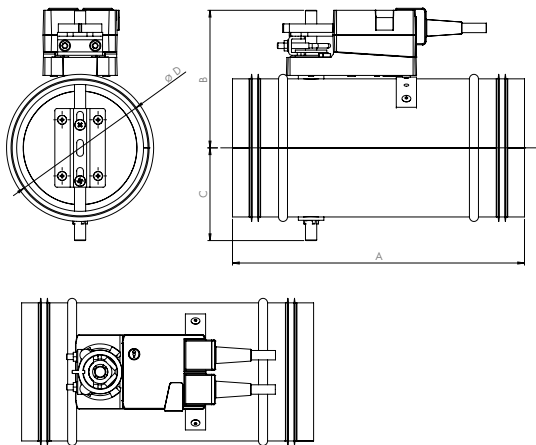

Exhaust hood flap closed:



Exhaust hood general exhaust (basic air flow rate):

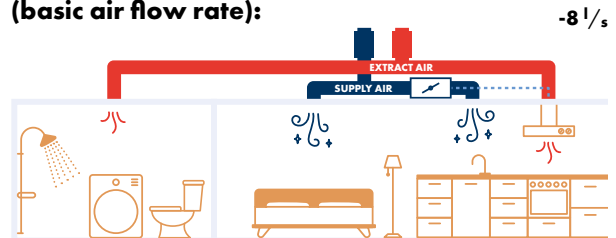

Exhaust hood flap open:

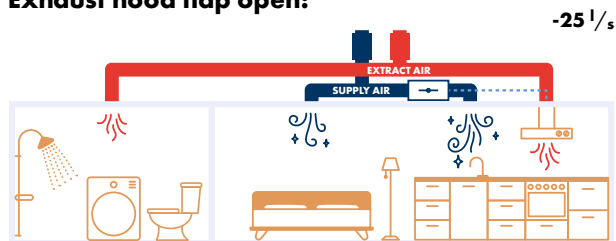

Model	P/N	LVI	øD	A	B	C	Type	Supply voltage	Exhaust hood
Santeri-125-LM24A	40000058	8417700	125	260	125	80	Compensator	24 V	Suvi, Ida and Eva
Santeri-125-LF24	40000059	8417701	125	260	160	80	Spring return actuator	24 V	Suvi, Ida and Eva
Santeri-125-LM230A	40000060	8417702	125	260	125	80	Compensator	230 V	Pia
Santeri-125-LF230	40000061	8417703	125	260	160	80	Spring return actuator	230 V	Pia

The damper is also available in size 160 mm (delivery).

Our sales team



ITÄ-UUSIMAA, LAHTI & EASTERN FINLAND

Mika Kasper
+358 (0)41 312 0109
mika.kasper@airfi.fi



SATAKUNTA, PIRKANMAA & NORTHERN FINLAND

Aki Löfgren
+358 (0)40 565 3843
aki.lofgren@airfi.fi



VARSINAIS-SUOMI & UUSIMAA

Toni Paavola
+358 (0)40 768 8773
toni.paavola@airfi.fi



AALAND ISLANDS & EXPORT

Petter Kronvall
+358 (0)40 820 8505
petter.kronvall@airfi.fi

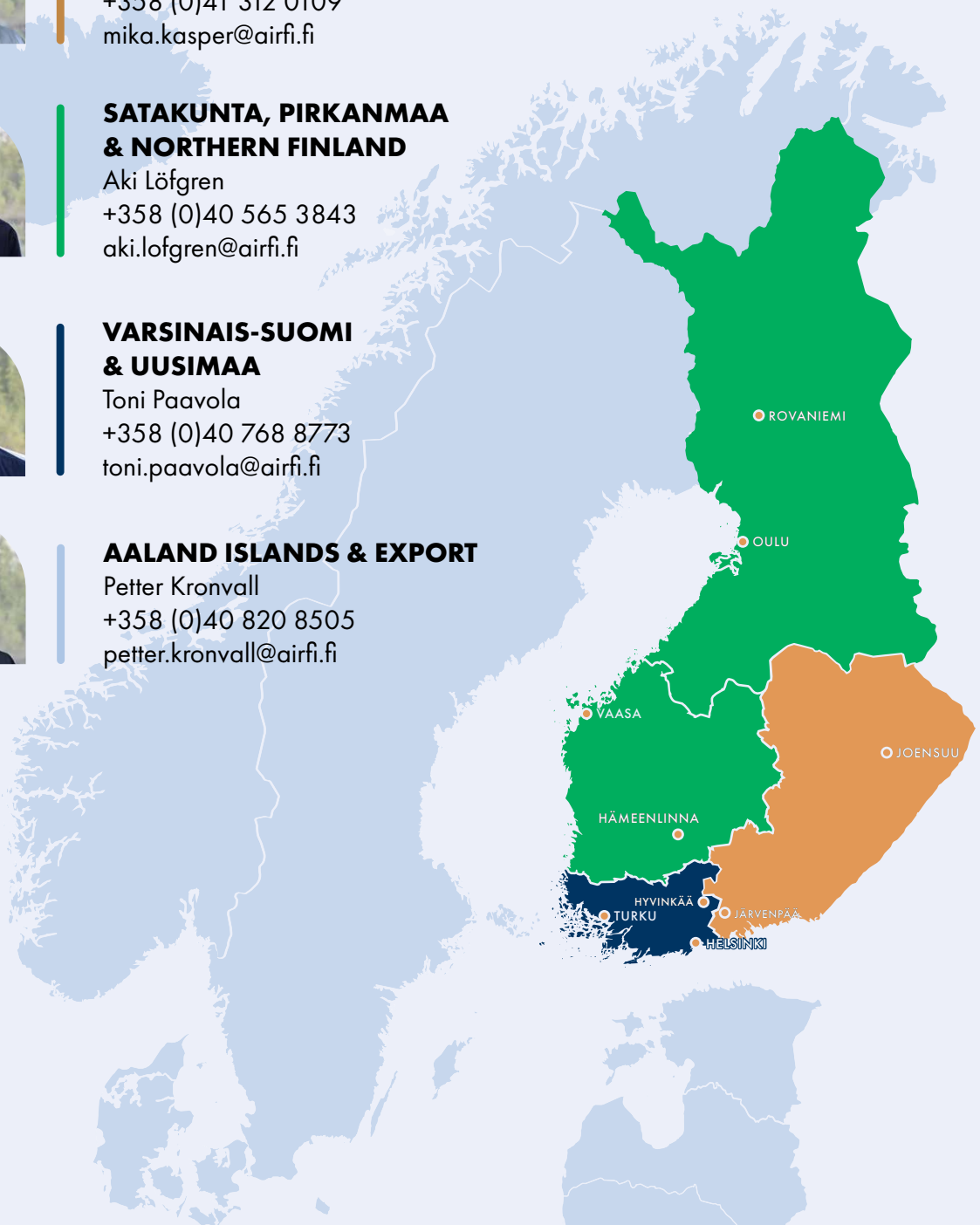

Airfi Oy AB
Piilipuunkatu 11
21200 Raisio, Finland

02 430 3300
airfi.eu
info@airfi.fi

REV B1-2024
60800225