

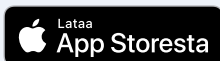

Model 250  
Model 350

Download **the Airfi App**  
to your smart device.

You get an easy-to-use weekly  
clock and many other functions.





# Table of contents

<b>Warnings and cautions</b>	<b>5</b>
<b>General information</b>	<b>6</b>
General information in brief	6
Basic operation of the air handling unit	6
Controls	7
Fans	8
Heat recovery cell	8
Protective functions	8
<b>Hauling</b>	<b>10</b>
<b>Installation</b>	<b>11</b>
Installation of ventilation ducts	11
Condensate removal	12
Airfi water seal	12
Electricity, control cables and controllers	12
Duct radiators	12
<b>Controllers</b>	<b>13</b>
Uno	13
Sento	13
Mille-Wire	13
Mille-Wifi	14
Airfi App	14
Airfi Cloud	14
Seven segment	14
Bus control	15
Exhaust hood controls	15
Constant pressure control	15
Filter guard alarm	15
Spring return dampers	15
Transmitter controls	15
<b>Commissioning</b>	<b>16</b>
Air flow rates	16
Basic air flow control	16
<b>Maintenance</b>	<b>16</b>
Opening	16
Filters	17
Heat recovery cell	17
Fans	17
Cleaning the duct system	17
Condensation water	17
Airfi water seal	17
Other maintenance	17
<b>Technical specifications</b>	<b>18</b>
Dimensional drawings	19
Potentiometric setup – Seven-segment	24
Air flow	26
Other functions	26

**Read the instructions for use, installation and maintenance carefully before proceeding.**

You can also download the instructions from our website: [www.airfi.fi](http://www.airfi.fi). The document is intended for anyone who services, installs or uses Airfi Oy's air handling units.

We reserve the right to make changes.

# Warnings and cautions

## Installation

**NB:**

For moving and lifting the unit, see page 10.

The installation of the air handling unit should only be carried out by an authorised person. Installation must be carried out with care and in accordance with the regulations and standards in force for installation, adjustment and commissioning.

## Electrical installation work

The unit must be disconnected from the mains when carrying out voltage tests, insulation resistance measurements or other operations on the mains which may cause damage to sensitive electronic equipment.

## Opening the unit

Stop the unit.

**NB:**

For electric models, wait until the unit has finished its run-on before opening the unit. The run-on time is the delay during which the thermal load of the electrical resistor is cooled before the fans are stopped / the dampers are closed. There is no run-on time in water models.

After the fans have stopped, switch off the power supply to the unit at the service switch. On page 16, you will find the instructions for using the door mechanism.

When carrying out maintenance work, make sure that the power supply to the unit is disconnected.

**NB:**

Cutting the power from the service switch cuts the power supply to all factory-installed components. There is still voltage on the primary side of the service switch.

## Drying laundry

We recommend that you do not connect a tumble dryer or drying cabinet to the extract air of the unit.

## Condensation water and condensation

In freezing temperatures, the surface temperature of the unit can temporarily drop so low that moisture can condense on the surface of the unit in humid conditions. Take this into account with regard to fixtures near the unit. Check the condensate drain pipe regularly to ensure that condensation water can drain freely into the drain.

## Commissioning

The unit should only be put into operation after the dust-generating work on site has been completed. The duct connectors of the air handling unit must be kept covered during transport, installation and storage. This keeps the ducts and the air handling unit clean and allows the unit to be commissioned without the need for additional cleaning.

**NB:**

This device is intended for use by adults. Children and persons with physical, sensory or mental limitations should only use the device with assistance.

# General information

## General information in brief

<b>Enclosure</b>	The enclosure class of the unit is IP34 when the hatch is closed
<b>Fans</b>	Airfi air handling units are equipped with energy-efficient EC DC fans. The fans can be controlled steplessly.  <b>NB:</b> On Airfi units, if a fan fails, you can disconnect the electrical connections from the finger connectors located outside the protected electrical compartment.
<b>Filter sets</b>  <b>Filter Set #3 - Model 250/350</b>	<b>Supply</b> ISO Coarse, 90%+ ePm1, 55%  <b>Extract</b> ISO ePM10 60%  Remember to replace the filters regularly, at least every six months. Use original Airfi Oy filters. You can easily order filters from our web shop: <a href="http://www.airfi.fi/verkkokauppa">www.airfi.fi/verkkokauppa</a>
<b>Heat recovery cell</b>	Heat recovery with counter-current technology in aluminium construction. Does not transfer odours or moisture. Suitable for all applications.
<b>Condensation water tray</b>	The tilted inner floor improves the removal of condensation water from the inside of the unit.
<b>Buzzer alert</b>	Gives a beep through the air handling unit housing.

## Basic operation of the air handling unit

People are spending more and more time indoors, so it is important what kind of indoor air you breathe. Airfi air handling units and exhaust hoods make the indoor air quality of your property excellent. Airfi's continuous ventilation efficiently provides ventilation for your property all year round. High-quality ventilation provides healthy indoor air in an energy-efficient way, without compromising living comfort.

In densely built buildings, ventilation is even more important. Ventilation removes moisture from the building. Ventilation prevents the transfer of moisture into structures and thus the growth of mould and fungal spores. The heat from the extract air is recovered, increasing energy efficiency.

With mechanical ventilation, fresh outdoor air is brought into the building through the unit. The air handling unit is equipped with efficient **ISO Coarse, 90% + ISO ePM 1 55%** filters, which filter the air coming from the outside to the inside. Remember to replace the filters regularly, at least every six months. On the extract air side, the heat exchanger is protected against dirt by **ISO ePM10 60%** filters.

The air handling unit heats the filtered supply air before it is released into the room. The incoming outdoor air is heated primarily by the heat of the air leaving the heat exchanger. Fresh supply air at the right temperature improves living comfort. Set the supply air temperature slightly lower than the room temperature. This ensures fresh indoor air and the air coming in mixes more effectively with the air in the room. The air handling unit must always be on. It only needs to be switched off for maintenance. This will ensure that the property has adequate ventilation and good living comfort.

Airfi recommends setting the supply air temperature to +17°C. Too high a temperature setting will increase energy consumption and the clean air blown into the room will not mix as well with the room air compared to if the supply air temperature is 3–4 degrees lower. If low temperature air is to be blown into the room, the risk of condensation in the duct system must be taken into account. This is why the factory setting for the minimum supply air temperature is 15°C. Please note that the air handling unit does not cool the supply air.

**Tip!**

If the duct system has been carefully insulated against condensation, even lower temperature air can be blown into the room.

## Controls

<b>Speed #1</b>	<b>Long absence</b> You can set the air flow rate very low, for example, when you are away for a long period of time.
<b>Speed #2</b>	<b>Absence / Low load</b> You can set the air flow rate low and use this speed when your home is not under much load.
<b>Speed #3</b>	<b>At home / Normal load</b> It is recommended that the air flow rates in the relevant building regulations be set for this speed.
<b>Speed #4</b>	<b>Boost / High load</b> Used, for example, in a situation where the house has a slightly higher than normal load.
<b>Speed #5</b>	<b>Boost / Maximum load</b> Used, for example, in a situation where there is a large number of people in the house, during a party, etc.

## Fans

Airfi units use EC DC fans. Replacing a fan does not require a person with an electrical work licence. The control and supply connections for the fans are fitted with plugs that do not present a risk of electric shock. Misuse is also prevented. Model250 and Model350 are equipped with pin plugs. When replacing a fan, switch off the power at the unit's service switch.

## Heat recovery cell

Airfi air handling units use counter-current heat recovery technology. In the heat exchanger, fresh air from the outside cannot mix with the air to be extracted. This prevents the transfer of odours and moisture to the air inside the building. The heat exchanger can be easily removed from the unit and, if necessary, washed with a mild soap solution and water (do not use a pressure washer). Make sure that the heat exchanger is dry after washing before putting it back in the unit.

Airfi units also have a "cool recovery" function, which works if the home has, for example, an air-source heat pump. The heat load of the home is not increased, but if necessary, for example, on a hot summer's day, the air entering the house is cooled by air extracted from the inside.

Airfi units also have an enhanced cooling function. The function must be activated by the user, after which the unit will operate independently at the set values. After activation, the unit monitors temperatures and boosts air volumes as needed depending on conditions. The fan speed during enhanced cooling can be limited so that, for example, at night the fan does not run at maximum power but at the maximum speed set by the user.

Airfi units also feature an advanced heat recovery bypass. The heat recovery cell can also be only partially bypassed, allowing this feature to be used, for example, in spring when the outdoor temperature rises during the day.

## Protective functions

<b>Fault reports / Buzzer</b>	<p>Airfi units are equipped with an alarm buzzer as standard. The buzzer will sound to signal an alarm. The buzzer alarm is only given for critical faults, for example, if a fan is broken or if an R model unit is installed in an L model duct system.</p> <p>The unit will continue to operate in a limited manner in the event of a fault and will return to normal operation once the fault has been rectified. You can search for a service centre in your area at <a href="http://www.airfi.fi">www.airfi.fi</a></p>
<b>Fan overheat protection</b>	<p>The fans have built-in overheat protection. If the overheat protection mechanism is tripped, the fan stops. The mechanism is automatically resettable, meaning that when the temperature drops, the fan will restart.</p>

<p><b>Airfi Frost Pro System – self-learning hoarfrost protection (AFPS)</b></p>	<p>AFPS technology is used to achieve A+ rated annual efficiency in the Model 250 and Model 350 air handling units manufactured by Airfi Oy. AFPS is standard in all air handling units manufactured by Airfi Oy. The new AFPS is a self-learning hoarfrost protection system which guarantees excellent performance during cold periods.</p> <p>Airfi Frost Pro System is a Finnish invention, where the heat exchanger is defrosted only when there is a need for it and the heat exchanger is guaranteed to work even in prolonged freezing weather.</p> <p>The energy used to defrost the heat exchanger is taken from the extract air. This way, the energy provided by the heating resistors is used in the apartment rather than, for example, heating the exhaust air with the front resistors.</p> <p>The defrosting function is used optimally, saving energy compared to older solutions. Model 250 and Model 350 have hoarfrost protection provided by block defrosting.</p> <p>The self-learning capabilities make it possible to take the individual characteristics of the air handling unit into account, for example, how dirty the filters and heat recovery cell are.</p>
<p><b>Electric heaters</b></p>	<p>Airfi automation is equipped with automatic self-reversing overheat protection. If the temperature gets too high, the supply to the resistor is cut off.</p> <p>In addition, the unit is equipped with mechanical overheat protection. If the mechanical overheat protection mechanism is tripped, the unit's electric heater cannot be switched on until the overheat protection activation is acknowledged. When the mechanical overheat protection mechanism is tripped, the cause of the tripping should always be determined.</p>
<p><b>Water radiator</b></p>	<p>The water radiator is protected by an anti-freeze function. When the temperature drops too low, the unit's automatic system stops the unit. An alarm will sound if the anti-freeze is activated. When the anti-freeze function is tripped, the cause of the anti-freeze tripping should always be determined.</p>
<p><b>Fire risk alarm</b></p>	<p>The unit has a built-in fire risk alarm. The fans stop if the temperature of the extract air exceeds +70°C or the temperature of the supply air exceeds +50°C. The parameters are configurable. The fans start to run again when the temperature drops (factory setting) or after reset. This function can be disabled by setting the value to 0.</p> <p>NB: For example, in the event of a fire risk alarm, you can choose whether the fans should start automatically or whether a reset is required.</p>

# Hauling

Airfi Model 250 and Model 350 are always delivered on a pallet.



**NB:**

The unit is attached to the pallet, so be sure to remove the fixing screws before lifting the unit.

The unit's paint surface is inspected and documented before the protective plastic is applied to the unit.

Airfi accepts no responsibility for any scratches on the paint surface during hauling/transport/installation.

The unit mounting feet and the screws for fixing the bottom cover strip are packed in a mounting bag, which is located on the top surface.

The unit's bottom cover strip is placed to the side of the unit during transport.

As a rule, we recommend hauling using the pallet on which the unit was delivered.

Alternatively, the unit can be hauled on a pallet truck, for example.

The unit can also be lifted with lifting slings. In this case, make sure that the lifting slings do not squeeze the frame during the lifting. Ensure safety when hauling the unit. The unit weighs approx. 175 kg.

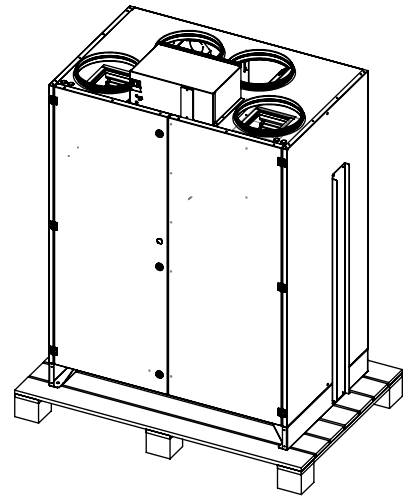

# Installation

The air handling unit should be installed in a room with a temperature of at least +10°C and where condensation drainage is possible. The air handling unit should not be installed on the wall opposite the bedroom or living room wall. When installing, care must be taken to ensure that the electrical and control cables are placed in an easily accessible location. The unit is always installed on the floor/on a fixed shelf. Note the possible resonance of the mounting platform. Typically, the best mounting platforms are solid structures, e.g. concrete.

Install the adjustment feet supplied with the unit and adjust the unit to a fully horizontal position according to the top surface of the unit. If the unit is not mounted horizontally, the doors may “bounce” slightly. Fix the unit horizontally using the adjustable mounting feet.

The connections to the air handling unit are made in the unit’s electrical box, which is located on the top surface of the unit.

## Installation of ventilation ducts

The instructions are general in nature. Install duct insulation according to the site plans.

Ventilation ducts and components are installed according to the HVAC plans. The installation of ventilation ducts should be carried out by an authorised installer. Correct and planned insulation prevents heat loss, moisture condensation and fire spread in ventilation ducts. Even small defects in insulation reduce sound absorption and pose a risk of condensation and indirect damage. The weight of the duct system must not put a load on the unit. In order to avoid structure-borne noise, ducts must not be installed directly against structures. In renovation projects, the insulation of the existing duct system should always be checked and, if necessary, insulation should be applied.

### General guidelines on insulation

The supply air duct must always be carefully insulated between the unit’s duct outlet and the silencer, so that the sound of the fan is not carried into the room. The supply air duct is insulated in a cold room.

- » The exhaust air duct is insulated according to country-specific requirements (e.g. fire rating).
- » In a warm indoor space, the outdoor air duct and the exhaust air duct are insulated and condensation insulation is also installed.
- » Extract and supply air ducts do not need to be insulated in warm indoor spaces. NB: If the supply air duct is located in a place with a high ambient temperature, we recommend insulating the supply air duct. (Note the condensation insulation in cooling)

The ducting through the vapour barrier to the attic must be done carefully. Silencers are placed in the supply and extract air ducts as close as possible to the unit. Make sure that the duct outputs of the unit you are installing correspond to the ducting of the site.

**NB:**

Before installing the unit, make sure that the handedness of the unit matches the ducting of the site.

**NB:**

The supply air duct must be condensed if indoor air is cooled through ventilation.

**NB:**

Make sure that the duct system is large enough for the desired air volume. If necessary, increase the duct size to achieve the desired air velocity in the main air duct.

## Condensate removal

Airfi units have a tilted inner floor, which allows the water at the bottom to drain out of the unit quickly. Condensation water is discharged from the unit through a condensation connection at the bottom of the unit. The connection has a 1/2" female thread.

Connect the optional Airfi water seal to the connector on the bottom of the unit according to the installation instructions provided with the water seal. To drain the water produced by the unit, you can also connect a drain hose or a drain pipe made by an installer to the drain connection, which allows condensation water to drain away from the bottom of the unit.

The inner diameter of the drain hose or pipe should be at least 12 mm. The drain hose or pipe must not be led directly into the sewer. The drain hose or pipe must not have two water seals or horizontal drains. The recommended minimum water seal height is 100 mm. Check that water can drain out of the bottom of the unit before starting it up. Pour water into the bottom of the unit and check that the water is draining out of the bottom of the unit.

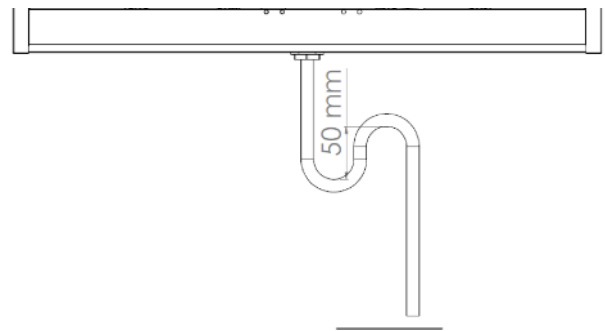

## Airfi water seal

The Airfi water seal is a silent ball valve water seal designed to remove condensation water from the unit. The water seal is suitable for use with all small air handling units. There should be about 14 cm of free space under the unit.

Model	Code	LVI number
Airfi water seal chrome-plated	40000053	7916072

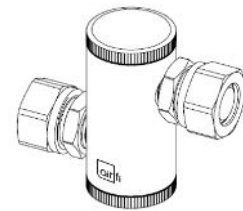

## Electricity, control cables and controllers

Model 250 Electric / Model 250 Water / Model 350 Water are equipped with a grounded plug (16 A), note the current rating on the socket.

The Model 350 Electric supply conductor is installed by an electrical contractor.

The control connections are located in the electrical box above the unit.









## Duct radiators

Cooling and heating duct radiators are available as an option for all Airfi models.

# Controllers

Individual instructions for controllers can be found in a separate document. Here is an overview of the controllers.

- » The air flow rates specified in the building regulations are recommended to be set at speed 3.
- » Air handling units and control hoods must always be fitted with an earthed plug.

 <b>At home / Away</b>	 <b>Service panel</b>	 <b>Controls multiple units</b>
 <b>Sauna function</b>	 <b>Boosting</b>	 <b>Wireless control</b>
 <b>Fireplace function</b>	 <b>Time programme</b>	 <b>Time and date</b>

## Uno

The Uno controller cannot be used if the unit has a constant pressure control. In this case, select the Sento or Wire controller.

The Uno control panel has five speeds. The Uno control panel can be flush-mounted into an appliance box or mounted in a surface box. Appliance boxes are not supplied with the controller.



E.g. Nomak 2x2x0.5+0.5



## Sento



Sento – hard-wired controller with touch switches. Sento has five speeds. An appliance box must be installed behind the control panel. Appliance boxes are not supplied with the controller.



E.g. Nomak 2x2x0.5+0.5



## Mille-Wire



The Mille-Wire controller is hard-wired. This controller is also used as a service panel. Installation height 1.6 m. An appliance box must be installed behind the controller. Appliance boxes are not supplied with the controller. The product is supplied with a mounting bracket.

The Mille controller is an easy-to-use modern controller with a touch screen. If you have connected the Airfi air handling unit to the internet, you will receive up-to-date weather information and air handling unit alarms on the Mille control panel screen (the Mille-Wire controller is updated via USB).



E.g. Nomak 2x2x0.5+0.5



**NB:**

We recommend using the Mille Wire controller when the unit is equipped with Constant Pressure Control or Filter Guards



## Mille-Wifi



Mille – a Wifi connected control tablet (if the internet switch in the apartment does not have Wi-Fi functionality, choose the Airfi Wire controller), the Mille Wifi controller works wirelessly, so you will need a USB socket to connect the controller to the power supply (installation height 1.6 m).

The Mille controller is an easy-to-use modern controller with a touch screen. If you have connected your Airfi air handling unit to the internet, the Mille control panel displays up-to-date weather information, air handling unit updates and other information to make your life easier.

We recommend using Mille Wire or Mille Wifi when the unit is equipped with Constant Pressure Control or Filter Guards.



Ethernet, CAT5 or higher.



**NB:**

When using Mille Wifi, the internet cable from the unit is connected to the Wi-Fi switch in the controlled space.

## Airfi App

An Airfi Oy supplied controller is not necessarily required to control an Airfi air handling unit. You can buy an app from the app store (Google Play Store or App Store [coming soon]) to control your air handling unit.



**NB:**

With app control, the unit's internet cable is connected to the Wi-Fi switch in the controlled space, and the app is purchased from the app store

## Airfi Cloud

Coming soon

You can connect one or more units to our cloud service, where you can monitor the unit's activity (subject to a fee).

## Seven segment

Local control from inside the unit without separate controls. Air volume and voltage setting without a Mille controller or other manual controls is done using the Seven-segment display inside the unit. (see pages 24–25)

## Bus control

Airfi air handling units have Modbus RTU and TCP/IP bus interfaces as standard. Connection to the KNX bus requires a separate adapter (accessory: Airfi KNX adapter, product code: 40 000 098).

The Modbus master map is available as a separate document on our website.

The unit is equipped for control-command centre connections. The unit can be controlled from the control-command centre, e.g. by dual-speed operation or a 0–10 V voltage signal. The supply air temperature can be controlled by a 0–10 V voltage signal. The speed of the unit can be scanned to the control-command centre with a 0–10 V voltage signal. Note the limited 0–10 V controls in the constant pressure setting.

## Exhaust hood controls

You can control the Airfi air handling unit with the control or booster hoods Pia, Suvi, Ida and Eva. Electronic hoods synchronise with the controls in real time.

## Constant pressure control

The unit can be fitted with constant pressure control on the supply and extract side (accessory, factory-fitted). The controller maintains the set pressure in the supply and extract ducts.

Constant pressure control with 1...5 steps

## Filter guard alarm

The unit can be fitted with a filter guard for supply and extract filters (accessory, factory-fitted). The filter guard is calibrated on site, after which the filter guard operates over the entire speed range (alarm limit curve adjustable).



**NB:**

Uno controller cannot be used with constant pressure control / limited 0–10 V controls

## Spring return dampers

Spring return dampers (accessory, factory-fitted) are closed if the fan is not running. Ready installed and connected.

## Transmitter controls

CO<sub>2</sub>, RH, VOC

# Commissioning

Air handling system settings during commissioning and maintenance can be made using the Mille-Wire service panel, the Mille Wifi control panel, the Airfi App or locally using the Seven-segment display (standard inside the air handling unit). The service code for the Mille panel is 12345. At the time of commissioning, at least the air flow rates must always be adjusted. The unit's controller has five speeds. The air flow rates specified in the building regulations are recommended to be set at speed 3 = "at home" position.

## Air flow rates

If necessary, a sizing and selection tool can be found on the Airfi Oy website. For unit-specific air flow curves, see page 20.

### Tip!

The set values should also be recorded on the label behind the unit cover strip.

The unit air flow rates are adjusted to the air flow rates specified by the ventilation designer. The automation also has the possibility to install restrictions on the maximum air flow rates (small apartments).

Remember to record the settings you have adjusted, so that, for example, if a circuit board breaks, the air flow rate does not need to be readjusted, but the values recorded can be set on the new board. It would be a good idea to record the set values of the Airfi units on the label behind the cover plate.

New apartments contain humidity due to construction, which is why we recommend keeping the ventilation at least at the air volumes specified in the building regulations. If ventilation is set to too low, moisture can condense on cool surfaces, such as windows.

## Basic air flow control

Before you start adjusting the air flow rates, open the unit and make sure there is no debris or objects that do not belong in the unit. Also check that the filters are clean.

# Maintenance

## Opening

Stop the unit.



### NB:

For electric models, wait for the unit to run down before opening the unit. The run-on time is the delay during which the thermal load of the electrical resistor is cooled before the fans are stopped / the dampers are closed. There is no run-on time in water models.

After the fans have stopped, switch off the power supply to the unit at the service switch. Please find attached the instructions for the door mechanism.

When carrying out maintenance work, make sure that the power supply to the unit is disconnected.



### NB:

Cutting the power from the service switch cuts the power supply to all factory-installed components. There is still voltage on the primary side of the service switch.

## Door locking mechanism opening/closing instructions

Handedness Right:

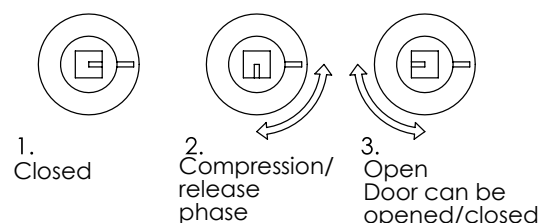

Handedness Left:

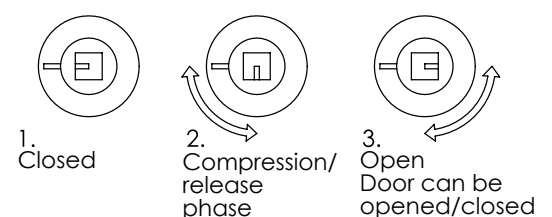

## Filters

Filter replacement every six months. The filter needs to be replaced more often if there is a lot of dust in the home or pollutants in the outdoor air. Open the door, remove the old filters from the unit and put the new filters in place. Always use original filters to ensure proper functioning. Filters are easy to order from [shop.airfi.fi](http://shop.airfi.fi)

Do not use the unit without filters.

### Filter sets and codes

Filter Set #3	Model 250-350	40000003
---------------	---------------	----------

## Heat recovery cell

The heat recovery cell must be cleaned every three years or more frequently if necessary. The cell comes off by pulling. Wash the cell with running water and a mild detergent (e.g. dishwashing liquid). We recommend cleaning the cell outside the heating season. Make sure the cell is dry before placing it in the unit.

## Fans

Clean and inspect every two years.

### Removal of fans

- » Disconnect the unit from the mains
- » Open the lid
- » Disconnect the finger connectors of the fan
- » Remove the fan mounting plate fixing screws, 2 pcs (Torx 20), at the front of the unit. (the entire fan mount and the vibration damper as well as the fan attached to the plate come off the unit as a whole)
- » Clean the fan with a soft brush and a vacuum cleaner. NB: the balancing strips on the fan blades must not be removed.
- » Put the fan assembly back in place and tighten the fixing screws
- » Connect the finger connectors

## Cleaning the duct system

Residential area and location have a significant impact on the cleaning intervals of duct systems. It is recommended that mechanical air handling systems be cleaned every 5–10 years. Remove the fans from the unit in order to clean it.

## Condensation water

The condensate drainage from the unit must be checked annually. Pour water into the bottom of the unit and check that the water flows well through the condensation drain. If the unit makes a pulsating noise, pour water onto the bottom of the unit.

## Airfi water seal

The water seal can be opened from above and below for cleaning. This way you can clean the drip pot and condensate ball. After cleaning, pour water on the bottom of the unit to make sure the water seal works.

## Other maintenance

Cleaning the inside of the unit by vacuuming or wiping with a damp cloth as necessary

# Technical specifications



Dimensions (width x height x depth)	998 x 1475 x 650	998 x 1475 x 650
Weight	168 kg	168 kg
Duct outlets	4 x 250	4 x 250
Kitchen bypass	-	-
Condensate fitting	From the front edge 128 mm	From the front edge 128 mm
Condensation water tray	Tilted condensation water tray	Tilted condensation water tray
Max. extract air flow rate (100 Pa)	Electric 954 m <sup>3</sup> /h (265 dm <sup>3</sup> /s) Water 954 m <sup>3</sup> /h (265 dm <sup>3</sup> /s)	Electric 1325 m <sup>3</sup> /h (368 dm <sup>3</sup> /s) Water 1325 m <sup>3</sup> /h (368 dm <sup>3</sup> /s)
Max. supply air flow rate (100 Pa)	Electric 893 m <sup>3</sup> /h (248 dm <sup>3</sup> /s) Water 875 m <sup>3</sup> /h (243 dm <sup>3</sup> /s)	Electric 1256 m <sup>3</sup> /h (349 dm <sup>3</sup> /s) Water 1242 m <sup>3</sup> /h (345 dm <sup>3</sup> /s)
Specific energy consumption (SEC) in a cold climate	A+	A+
Specific energy consumption (SEC) in an average climate	A	A
Extract air heat recovery annual efficiency class	A+	A+
Air handling unit's specific electrical power class at rated air flow	A	A
Electricity	Electric 230 V 16 A, max. 3500 W Water 230 V 10 A, max. 1100 W	Electric 400 V 3 x 16 A, max. 8250 W Water 230 V 10 A, max. 1100 W
Apartment size max. m <sup>2</sup> *	450 m <sup>2</sup>	550 m <sup>2</sup>
<b>Summer/winter function</b>		
Automatic, adjustable	Standard equipment	Standard equipment
<b>Defrosting automation</b>		
Continuous supply air (AFPS)	Standard equipment (block defrosting)	Standard equipment (block defrosting)
<b>Post heater</b>		
	2380 W (electric) / water	3 x 2380 W (electric) / water
<b>Equipment</b>		
Ceiling mount bracket	Not available	Not available
Wall mount bracket	Not available	Not available
Mounting set	Standard equipment	Standard equipment
Vapour barrier filler plate	Not available	Not available
Humidity transmitter (internal)	Accessory	Accessory
Humidity transmitter	Accessory	Accessory
Carbon-dioxide transmitter	Accessory	Accessory
Cooling radiators	Accessory	Accessory
Filter guard	Accessory	Accessory
Constant pressure control	Accessory	Accessory
Spring return damper	Accessory	Accessory
Airfi KNX adapter	Accessory	Accessory
<b>Controller options</b>		
Uno, Sento, Mille-Wire, Mille-Wifi	Compatible	Compatible
Control hoods	Compatible	Compatible
VAK, DDC, 10VDC, Transmitter controls Modbus RTU/TCP, Ethernet	Compatible	Compatible

# Dimensional drawings

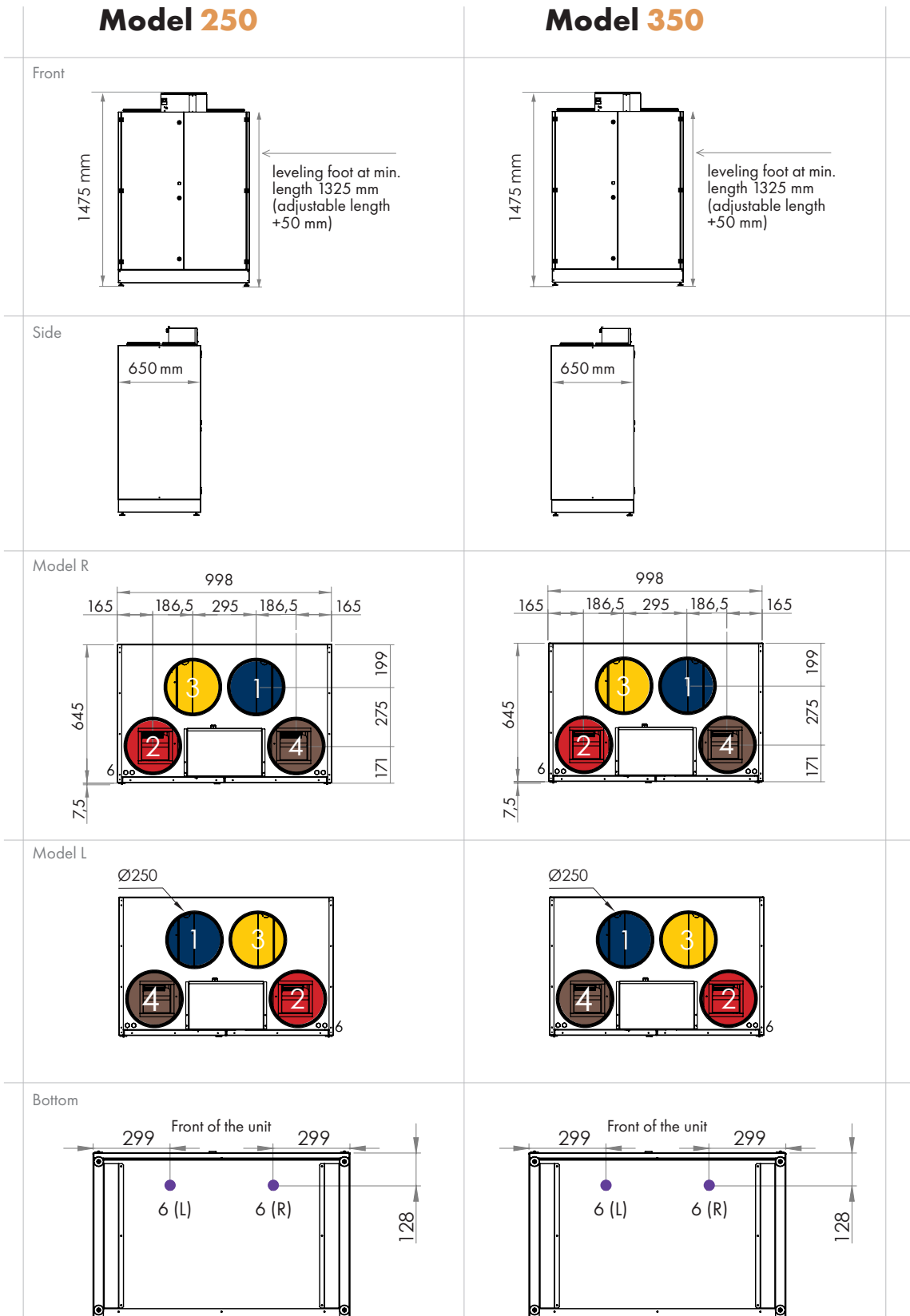

- Outdoor air (1)
- Supply air (2)
- Extract air (3)
- Exhaust air (4)
- Kitchen bypass (5)
- Condensate outlet (6)

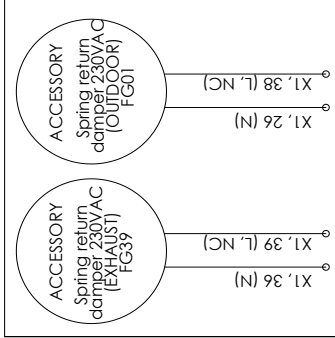
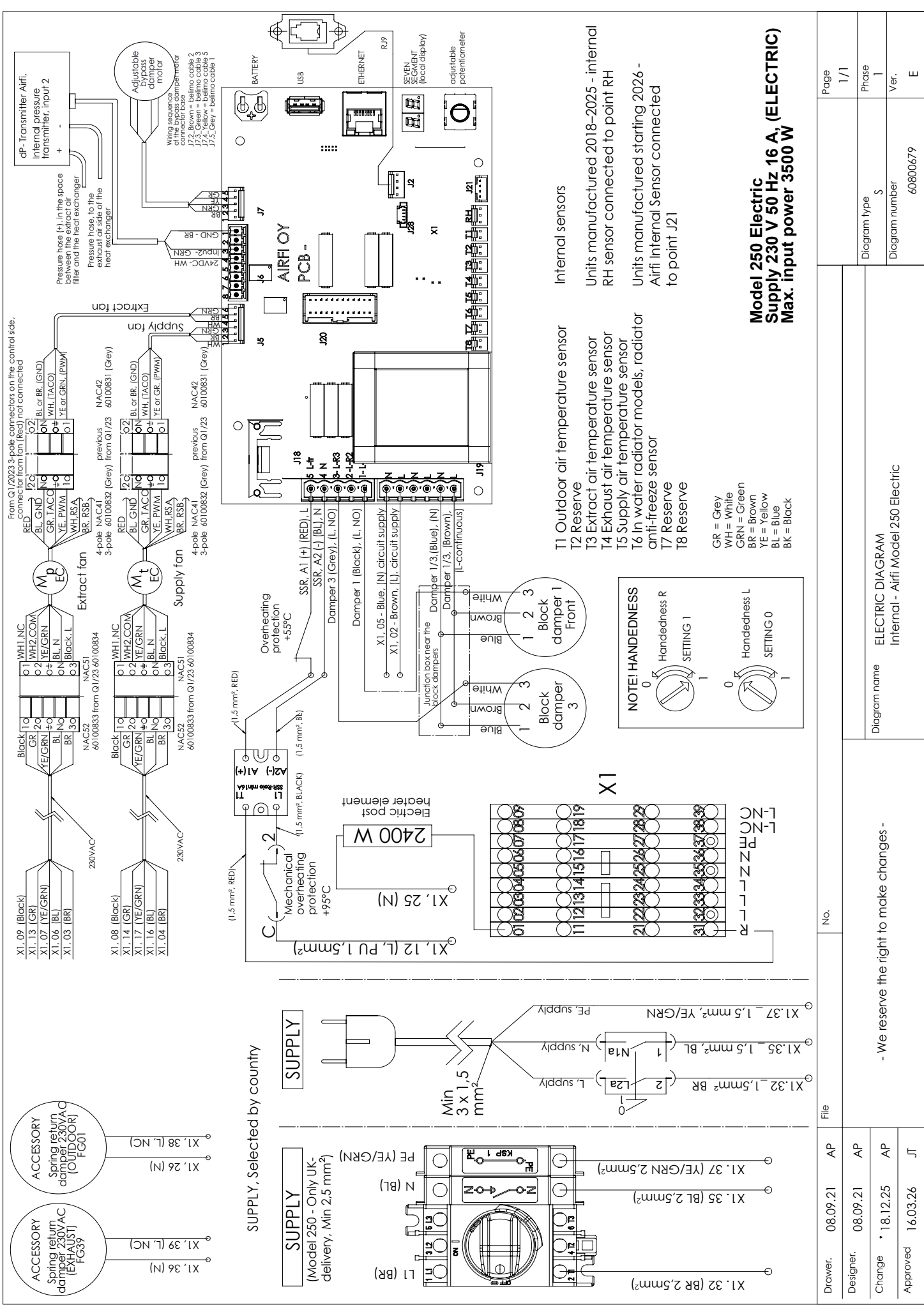

**SUPPLY, selected by country**

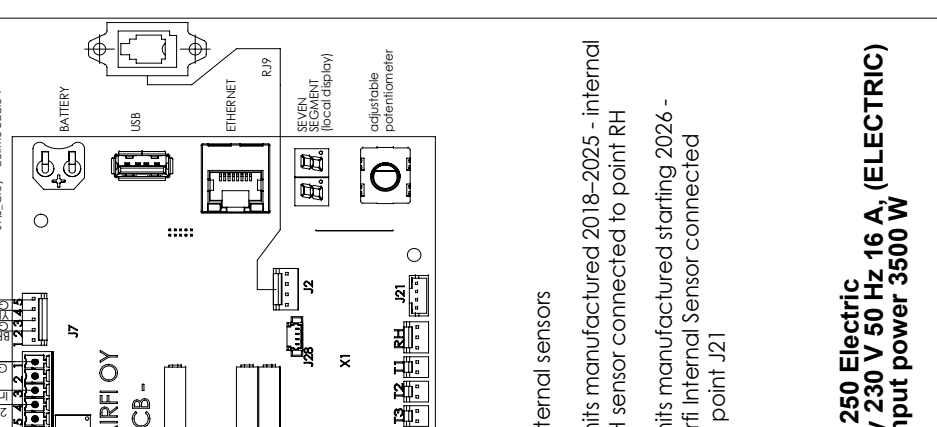
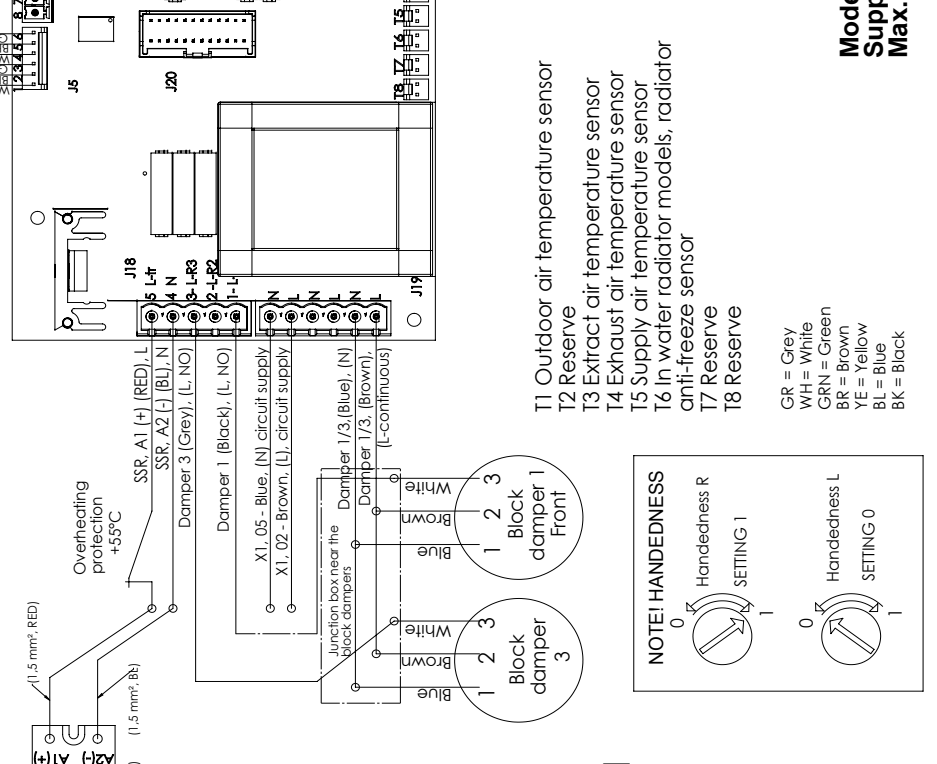
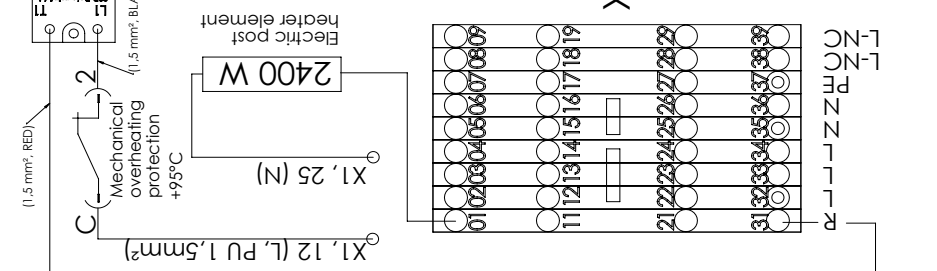
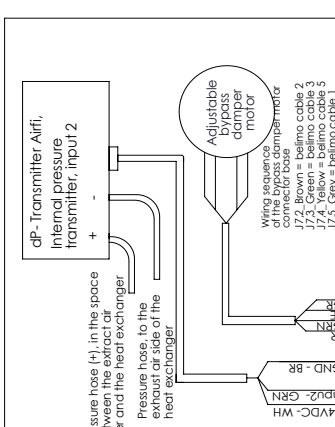
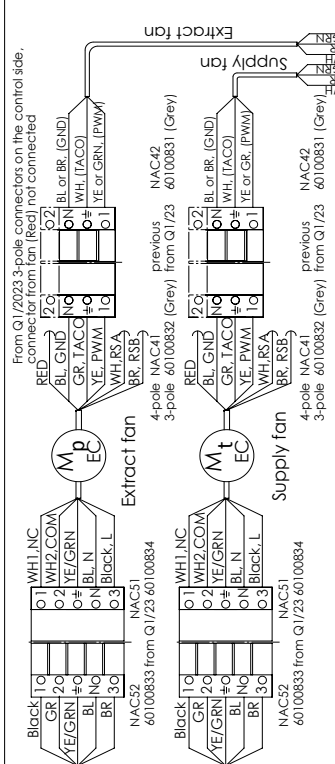
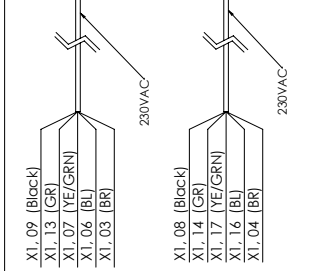
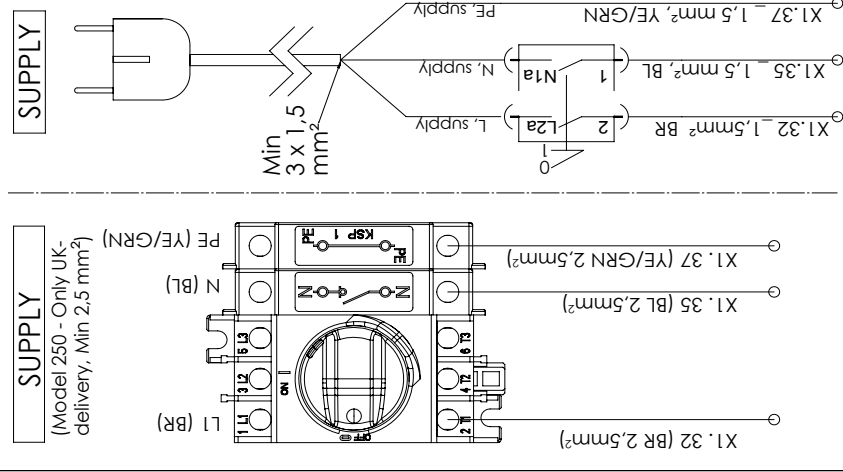

Drawer:	08.09.21	AP	File	No.	
Designer:	08.09.21	AP	- We reserve the right to make changes -		
Change	18.12.25	AP			
Approved	16.03.26	JT			
			Diagram name	ELECTRIC DIAGRAM	Diagram Type
			Internal - Aifri Model 250 Electric		S
			Diagram number		60800679
			Ver.		E
			Page		1/1

**Model 250 Electric**  
Supply 230 V 50 Hz 16 A, (ELECTRIC)  
Max. input power 3500 W

Internal sensors  
Units manufactured 2018-2025 - internal RH sensor connected to point RH  
Units manufactured starting 2026 - Aifri Internal Sensor connected to point J21

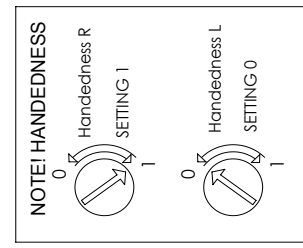









**Emergency Stop Function: unit shutdown (e.g. when the fire damper alarm is triggered) Function status indication forwarded e.g. to electrical control hood or to Modbus**

Connectable devices: e.g. fire dampers, condensate drain pump, sub control unit (SCU), potential-free status (suitable for low voltage +24 VDC, unit-specific wiring)

+24 VDC jumpering from the control board (e.g. supply to Sub Control Units or fire dampers → potential-free status) Status signal transmitted via Modbus or to electrical control hoods.

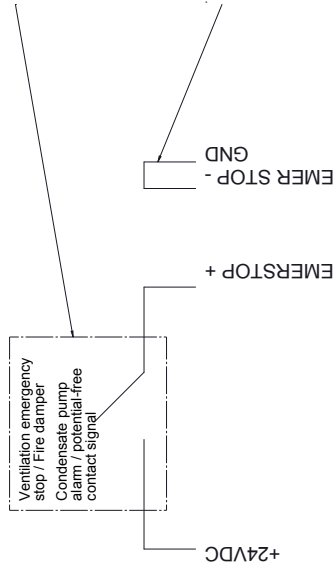

**INFORMATION:**

1. Normal operation: contact signal open.
2. Emergency stop active: contact signal closed.

If there are two fire dampers or other devices → connect in parallel. When connected in this way, an alarm will also be generated if either of the alarm-triggering devices issues a stop command.

Do not connect multiple units together / linked from the same EMER STOP pin.

Install a jumper in the connection box between GND and EMER STOP –

**NOTE!** INCORRECT WIRING WILL DAMAGE THE CIRCUIT BOARD.

**Physical connection: To be made according to the diagram shown below.**

Note! When connected in this way, the unit's +24 VDC can be jumpered to the Sub Control Units (SCU), fire dampers or condensate drain pump alarm signals routed through the unit's connection box (do not connect multiple apartments/units in the same chain when wired this way).

All connection points are located in the Airfi unit's external connection box.

**Signal to the electrical Airfi control hood (e.g. Airfi Savi, Airfi Ida, Airfi Eva):**

If a fire damper is activated or an external ventilation emergency stop command is received → the Airfi air handling unit will stop, and the symbol "P" will appear on the display of the electrical control hood.

The unit will not restart until the emergency stop signal has been cleared.

**Signal to Modbus RTU or Modbus TCP/IP:**

Ventilation emergency stop function via Modbus = in this case, e.g. fire damper activated → the status is transmitted to Modbus as a ventilation emergency stop signal. Register: 3x00017

**Reset of critical alarm signals**

The reset method for the function can be selected via Modbus register 4x00027. Normally, for example after the fire damper has been restored, the unit will automatically resume operation.

The register can also be configured to require a separate reset via Modbus, if any of the following alarms have stopped the unit.

Ventilation emergency stop, Fire hazard alarm, In water-based models: water heating coil frost protection alarm.

**NOTE!** The above connection can be implemented with AIRFI units without any additional devices.

**Carry out the connections with the power disconnected!**

-We reserve the right to make changes-

**Modbus RTU**

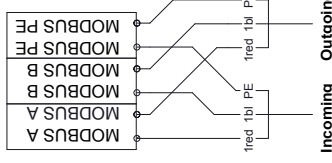

**Incoming Outgoing**

**MODBUS**

JAMAK  
2x(2+1)x0,5+0,5  
(Terminal pins doubled starting from 2026)

Modbus RTU and Modbus TCP can be controlled / read in parallel.

**Modbus TCP**



Ethernet Cable  
CAT 5E/CAT6/CAT7

Cable clearance 1,6 m  
(if needed, the wiring route out of the box is ready)

**MODBUS**

**This guide applies to the following models**

- Airfi Model 53mini Electric,
- Airfi Model 60 Electric,
- Airfi Model 100 Electric,
- Airfi Model 130 Electric,
- Airfi Model 150 Electric
- Airfi Model 250 Electric
- Airfi Model 250 Water
- Airfi Model 350 Electric
- Airfi Model 350 Water
- Airfi Model C5 Electric
- Airfi Model C5 Water

<p><b>CONNECTION POINTS</b></p>		<p>Diagram name S</p>	<p>Page 1/1</p>
<p>Design 23.04.24 AP</p>	<p>Diagram name ELECTRIC DIAGRAM additional information Principle scheme: Emergency stop, Condensate drain pump, SCU, Indication, Fire damper connection Airfi</p>		<p>Ver. 1/1</p>
<p>Update 11.05.2025 AP</p>	<p>Diagram type 60800754</p>	<p>Ver. C</p>	

# Potentiometric setup – Seven-segment



**NB:**

The potentiometer is active after 30s from the moment the unit is powered on.

## Setting the supply air temperature.

Start: 7-segment display shows no signs

1. Press the potentiometer once to display the temperature at which the supply air is set
2. Turn the potentiometer clockwise or counter clockwise to the desired temperature
3. Press the potentiometer again to save the value.
4. The programme moves on to the setup menu. Wait a moment until the automatic exit from the setup mode.
5. The supply air temperature can also be found in C1.

<b>A</b>	Adjusting the extract fan speeds
<b>B</b>	Adjusting the supply fan speed
<b>C</b>	Post heater
<b>D</b>	Settings for controls
<b>E</b>	Error
<b>F</b>	Heat recovery bypass
<b>H</b>	Hoarfrost protection
<b>I</b>	Other settings
<b>U</b>	Modbus
<b>N</b>	Cooker hood / fireplace / central vacuum cleaner overpressure function / sauna
<b>U</b>	Modbus
<b>P</b>	Boost settings
<b>Y</b>	Settings
<b>&lt;&lt;</b>	Back, return

<b>A</b> Adjusting the extract fan speeds			
A1	Extract fan speed 1	range 25...99, factory setting 30	
A2	Extract fan speed 2	range 25...99, factory setting 40	Model 250 ranges: 25...75, max 75 Speed 5, default 75 NB: Speed 5 control is also the maximum speed of the unit (the unit cannot run faster than the set value)
A3	Extract fan speed 3	range 25...99, factory setting 55	
A4	Extract fan speed 4	range 25...99, factory setting 75	
A5	Extract fan speed 5,	range 25...99, factory setting 99.	
<b>B</b> Adjusting the supply fan speed			
B1	Supply fan speed 1	range 25...99, factory setting 30	
B2	Supply fan speed 2	range 25...99, factory setting 40	
B3	Supply fan speed 3	range 25...99, factory setting 55	Model 250 ranges: 25...75, max 75 Speed 5, default 75
B4	Supply fan speed 4	range 25...99, factory setting 75	
B5	Supply fan speed 5	range 25...99, factory setting 99	
<b>C</b> Post heater settings			
C1	Desired supply air temperature (default window)	range 0...12–26 °C, factory setting +17 °C	Temperature set point (same set point for heating/cooling)
C2	Resistor connection temperature	range 0...+8 °C, factory setting +8 °C	when the outdoor air temperature T1 is higher than the set temperature, the resistor is not switched on
C3	Desired "away" mode temperature	range 526 °C, factory setting +17 °C	Temperature set point in "away" mode
C4	Limit value for the risk of freezing of water radiator	range 5–20 °C, factory setting 8 °C	NB: Only water units 250/350
C5	Post-ventilation time, electrical resistor	0–10 min, factory setting 3 min	NB: Only electric units 250/350
C6	Electronic actuator, post heater	0 = not enabled, 1 = enabled, default: 0	NB: Only water units 250/350
<b>D</b> Settings for controls			
D1	Joint adjustment	ON/OFF, default OFF = 0 = not selected	
D2	Joint adjustment control value	-99...+99	Joint adjustment control of the supply fan in relation to the extract fan, same adjustment at all speeds
D3	Compensation or stop, junction box pins 1,2,3	0,1 Factory setting 1	= 1 selected for exhaust hood compensation, 0 = selected to stop the unit when the contacts open, factory setting 1
D4	If D3 exhaust hood compensation is selected, the speed of the supply fan relative to the extract fan in the compensation situation	-99...+99 (factory setting 0)	
D5	Selected minimum speed when opening the exhaust hood booster valve	speed 3–5 (factory setting 4)	
D6	Control speed = to which position the required air flow is set	1–5 (factory setting 3)	
D7	Operating principle of the AUX2/OUTD. VALVE connector	0 = outdoor air damper relay control (factory setting) 1 = solution radiator, location in supply air duct (cooling) 2 = solution radiator, location in outdoor air duct (pre-heating/cooling)	
D8	Cooling mode temperature limit (T1 monitoring if D7 = 1)	10–25 °C (factory setting +17 °C)	
D9	Pre-heating temperature limit (D7 = 2)	-6...-2 °C, default -4 °C	
<b>E</b> Error info			
E0	General alert		More information in the app or on the Mille controller
E1	External shutdown of all unit fans, MODBUS or Ethernet command		
E2	The bypass does not work as intended		Check the operation of the bypass damper

E3	Supply fan not running		Fan controls or fan defective
E4	Extract fan not running		Fan controls or fan defective
E5	Radiator anti-freeze	Only in water models, will be removed when the conditions for starting the unit are met again	
E6	Sensor error		Flashing E6 and the sensor that is broken
E7	Hoarfrost protection pressure transmitter broken		
E8	Supply and extract fan temperatures incorrect		Check the handedness of the unit
E9	Constant pressure control alarm		
<b>F</b>	<b>Heat recovery bypass</b>		
F1	Bypass setting temperature	range +15...+30°C (factory setting +22°C)	
F2	Permissible lower limit for outdoor air bypass	range 5...30°C, default +9°C	
F3	Bypass delay	range 5...20 min, setting 5 min	
F4	Minimum supply air setting	range +10... +25°C (factory setting +14°C)	
<b>H</b>	<b>Hoarfrost protection</b>		
H1	Selected hoarfrost protection programme	1	default 1 – Airfi Pro Frost System
H2	Hoarfrost protection level (sensitivity)	0...10 (factory setting 5, neutral)	In range 6–10, the hoarfrost protection is more active than in the neutral level.
H3	<i>Not in use, reserve</i>		
H4	Forced defrost	The function performs a 30-minute forced defrost, after which it automatically returns to normal mode	
<b>I</b>	<b>Other settings</b>		
I1	Fire risk alarm, extract	0–99°C, 0 = off	default 70°C
I2	Fire risk alarm, supply	0–99°C, 0 = off	default 50 °C
I3	Startup delay	30–99 s	default 60 s
<b>U</b>	<b>Modbus</b>		
U1	Modbus ID	1–99 (controller - 1-253) - constant 1)	
U2	Modbus traffic speed	9600,19200,38400,57600,115200	11,22,33,44,55 (flashing)
U3	<i>Not in use, reserve</i>		
U4	Modbus bus parity	0,1,2	0=None (constant), 1=Odd, 2=Even
U5	Modbus bus stop bits	1,2	1 (constant), 2
<b>N</b>	<b>Cooker hood / fireplace / central vacuum cleaner overpressure function / sauna / maintenance</b>		
N1	Overpressure function time	0...30 min, factory setting 15 min	e.g. fireplace
N2	Overpressure function delay	0...30 min, factory setting 0 min	e.g. fireplace
N3	Overpressure function supply fan speed	0...99%, factory setting 70	e.g. fireplace
N4	Overpressure function extract fan speed	0...99%, factory setting 35	e.g. fireplace
N5	Sauna function activity time (prevents the humidity transmitter from boosting for the specified time)	0.5 h, 1.0 h, 1.5 h, 2.0 h, 2.5 h, 3.0 h, 3.5 h, 4.0 h	The time when the internal humidity transmitter does not automatically increase ventilation. When the time ends, the boost function starts automatically.
N6	Service reminder interval	0–6 times a year. Default 0	E.g. filter replacement
<b>P</b>	<b>Boost settings</b>		
P1	Panel booster function (Mille/Sento)	0...100%, factory setting 30%	Boosts the existing speed by the specified percentage, time set from the panel
P2	Boosted cooling allowed/not allowed	0 = Not allowed (factory setting) 1 = Allowed (user activation permission required to enable the function)	
P3	Control factor for boosted cooling	10–100% (factory setting 15%)	(more fan power if the desired temperature is not reached)
P4	Operation of the internal humidity transmitter	Fan function when humidity increases: 0 = Switch function / 1 = Transmitter function (default) / 2 = Disabled (250/350 default 2)	
P5	Setpoint for internal humidity transmitter	50...90%, factory setting 70%	
P6	Boost rate of the internal humidity transmitter if switch function selected	30...100, factory setting 60%	
P7	Average temperature of the daily T1 measurement at which the humidity transmitter must not boost	+15...+22 (factory setting +20 degrees)	
P8	Control factor in humidity transmission	10–100% (factory setting 15%)	
P9	Humidity transmission anomaly	1–5 % (factory setting 5 %)	
<b>Y</b>	<b>Settings</b>		
Y1	Factory setting reset	-> Step 1, still requesting Y or N	Restores factory settings (fan settings and Modbus parameters are not changed)
Y2	Backup card -> USB		
Y3	Restore USB -> card	-> Step 1, still requesting Y or N	
Y4	Save the log to USB		
Y5	Software version	Displays the display version	
Y6	TRIAC test	Triac operation test	
Y7	Ethernet connection active	1 = Connected / 0 = No connection	Displays the status of the Ethernet connection.
Y8	Activate remote logging	0 = Off / 1 = On	Requires an Ethernet connection.
Y9	Fixed IP address reset	DHCP is activated again	

## Air flow

The Airfi calculation programme calculates accurate octave-band sound power levels of the air flow in the duct system and the environment. The programme also calculates the control percentages for both fans and the SFP value according to the given air flow and duct pressure drop. The programme also shows the unit's annual efficiency. This document can also be used as an appendix to an application for a building licence.

### Model 250



### Model 350

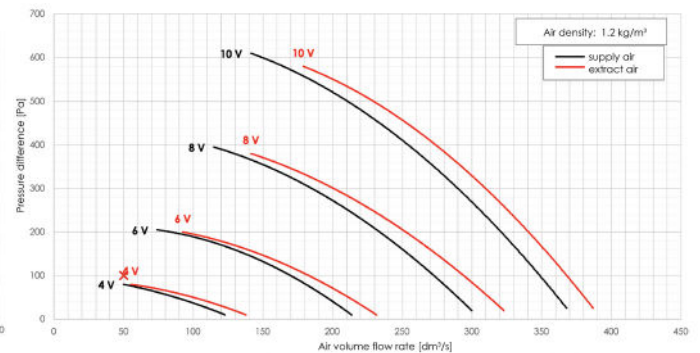

## Other functions

### Ventilation emergency stop - and + function

When a command comes in, stops the fans = control value for fan 0, regardless of what else the controllers request

**NB:** When the circuit is open, the unit runs normally. If 24 V DC is applied to the circuit, the unit will stop.

### Status out - gnd function

Gives out the speed of the unit as a voltage signal

#### Dual-speed operation

0 = unit stopped

Speed 1 (connected circuit closed between Speed1-24V-com) output voltage 1.0 V

Speed 2 (connected circuit closed between Speed2-24V-com) output voltage 2.0 V

#### 0-10 V direct control, threshold voltage 2.5 V = 25% then fans are allowed to start

0 = unit stopped

(between SPEED1-GND, voltage value 0.0 V-2.49 V)

0-10 V direct control, stepless between 2.5 V = 25% ..

10 V = 100 %,

gives out a value corresponding to the fan speed 2.5...10V

E.g. between SPEED1-GND is passed 50%=5.0 V control command -> equivalent is fed out of this 50 % = 5.0 V

**NB:** Not used in limited constant pressure control

## DECLARATION OF CONFORMITY

We declare that Airfi Oy's Model air handling units and exhaust hoods comply with the following EC Directives:

Machinery Directive (2006/42/EC)  
Low Voltage Directive (2014/35/EC)  
EMC Directive (2014/30/EC)  
WEEE Directive (2012/19/EC)  
RoHS Directive (2011/65/EC)

and that the following harmonised standards have been applied:

EN 13141-7 (2010)

A handwritten signature in blue ink, appearing to read "Izabella Lundberg".

Izabella Lundberg  
Toimitusjohtaja  
Airfi Oy AB

-We reserve the right to make changes -



**Airfi Oy AB**  
Piilipuunkatu 11  
21200 Raisio, Finland

+358 (0)2 430 3300  
[www.airfi.fi](http://www.airfi.fi)  
[info@airfi.fi](mailto:info@airfi.fi)

REV D1  
60800749